

Modelling and Simulation of DFIG based wind energy system

Aishwarya Ravichandran¹, Aashay Naik²
¹Vellore Institute of Technology, Vellore, Tamil Nadu, India.
²Vellore Institutes of Technology, Vellore, Tamil Nadu, India.

Abstract:- The paper represents the modelling and simulation of DFIG based wind energy system in the graphical environment SIMULINK. Here, we have tested the wind power system for three fault conditions and analysed the results.

Keywords:- SIMULINK, DFIG, pitch controller, fault conditions, converter bridges

I. INTRODUCTION

The demand for electrical energy in developing countries is ever increasing but the availability of fossil fuels is limited. One of the non-conventional resources that is subject to increasing research is wind energy. Wind turbines can be used as stand-alone or as a part of hybrid systems combined with solar energy or fossil fuels. This paper provides a detailed modelling of a wind power system based on doubly fed induction generator. The DC voltage from the wind turbine is fed into a converter for grid applications. The specifications of the wind farm have been taken from Vestas in Denmark.

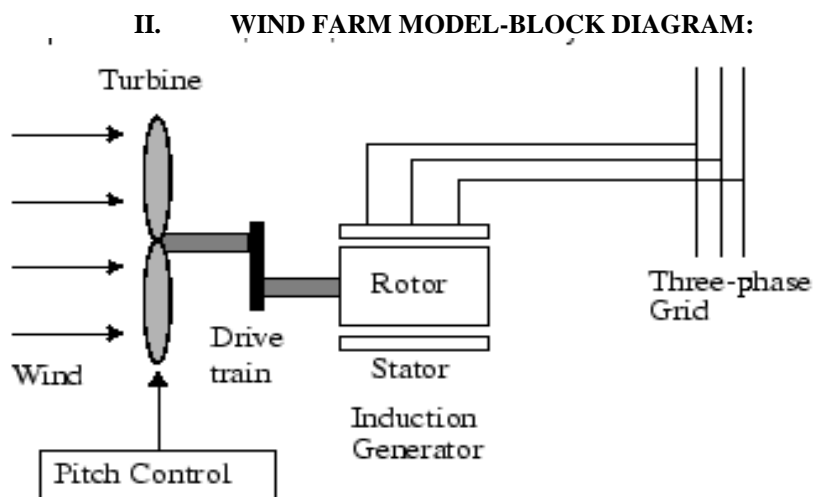

Pitch Angle Control System

Figure _1: Pitch angle control system

Here, the stator is directly connected to the grid while the rotor is driven by the wind turbine. The power from the turbine is converted to electrical power by the DFIG installed in the wind mill. At high wind speeds, the pitch angle controls the exceeding power by the IG. The induction generator is connected to a converter which provides the feedback to the grid. A capacitor bank can be added to the grid to compensate for the reactive power but the use of DFIG mostly eliminates it.

III .WIND FARM MODEL

The model in Fig.1. is a detailed model of DFIG based wind farm with the following subsystems:

1. DFIG and subsystem
2. Converter Bridges
3. Transmission and Grid
4. Wind turbine controller
5. Filter

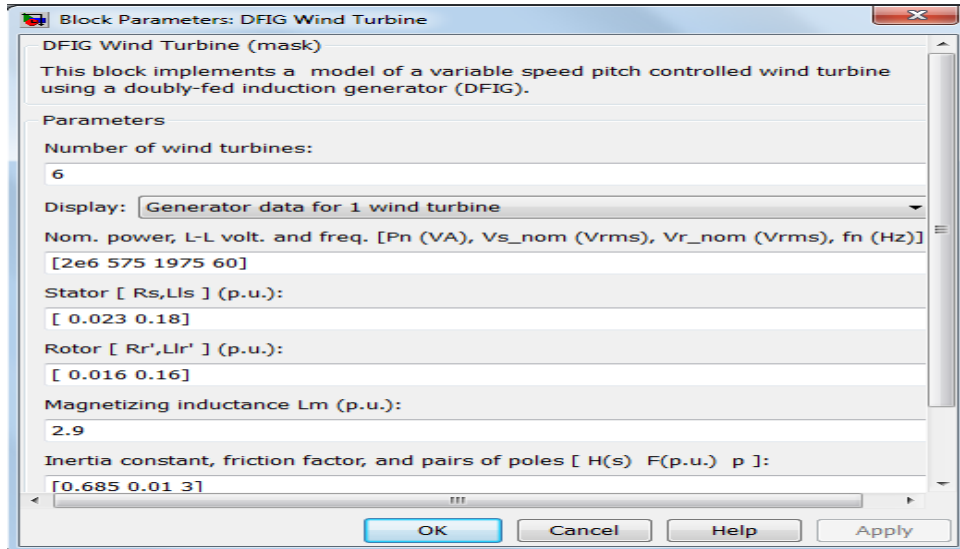

Figure_4: DFIG block parameters

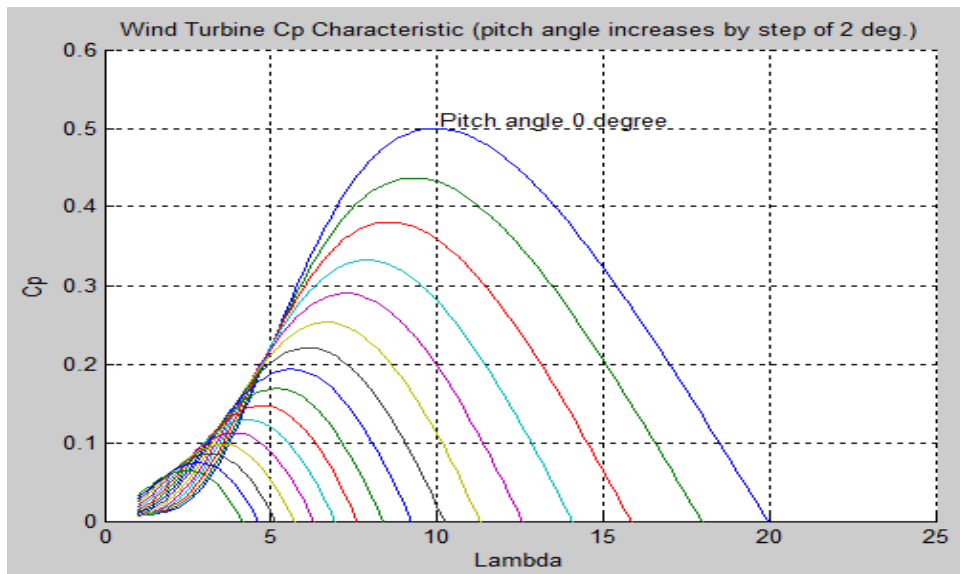

Figure_5: Wind turbine Cp characteristics

A wind turbine extracts the kinetic energy of the wind and provides to the rotor. The power extracted is given by:

$$P = \frac{1}{2} C_p \rho V^3 A$$

where P power (W),

C_p power coefficient,

V Wind velocity (m/s),

A swept area of rotor disc (m²),

ρ density of air (1.225 kg/m³).

The power coefficient is denoted by C_p which is a measure of the wind energy extracted by the turbine. It is different for different rotor designs and wind speeds. However, it can attain a maximum practical value of 0.4. The wind farm specification has

$$C_p(\lambda, \beta) = 0.5176 \left(\frac{116}{\lambda_i} - 0.4\beta - 5 \right) e^{-\frac{21}{\lambda_i}} + 0.0068\lambda$$

Where,

$$\frac{1}{\lambda_i} = \frac{1}{\lambda + 0.08\beta} - \frac{0.035}{\beta^3 + 1} \quad \text{Generator data} \rightarrow$$

VI. PITCH CONTROLLER

Pitch angle, beta is controlled with the help of a PI controller inside the wind turbine to maintain the electric power output under the nominal value. When the electric power increases beyond its nominal value, the PI controller increases the pitch angle to bring it back to the nominal value.

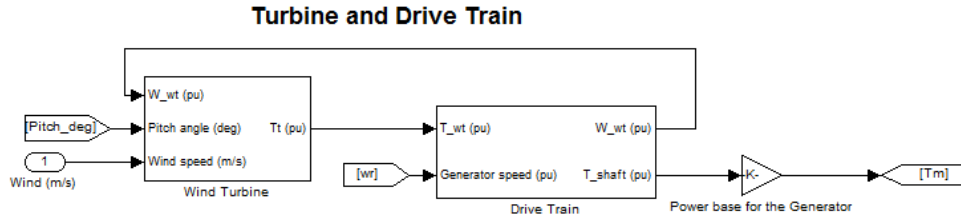

Figure_6: Turbine and drive control system

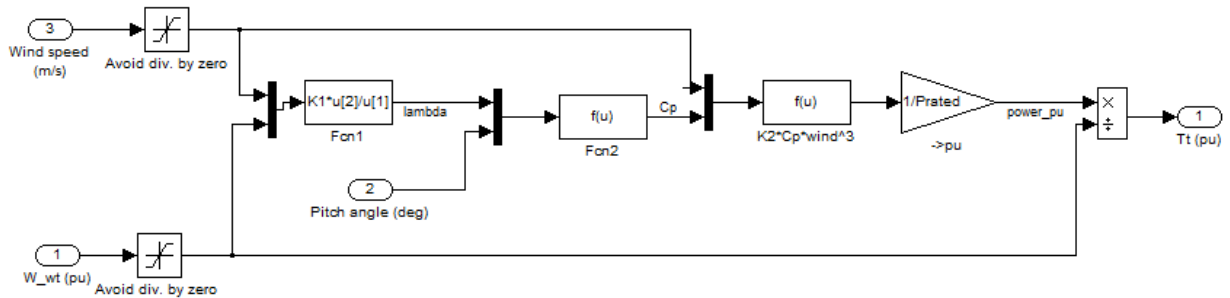

VII. CONVERTER BRIDGES

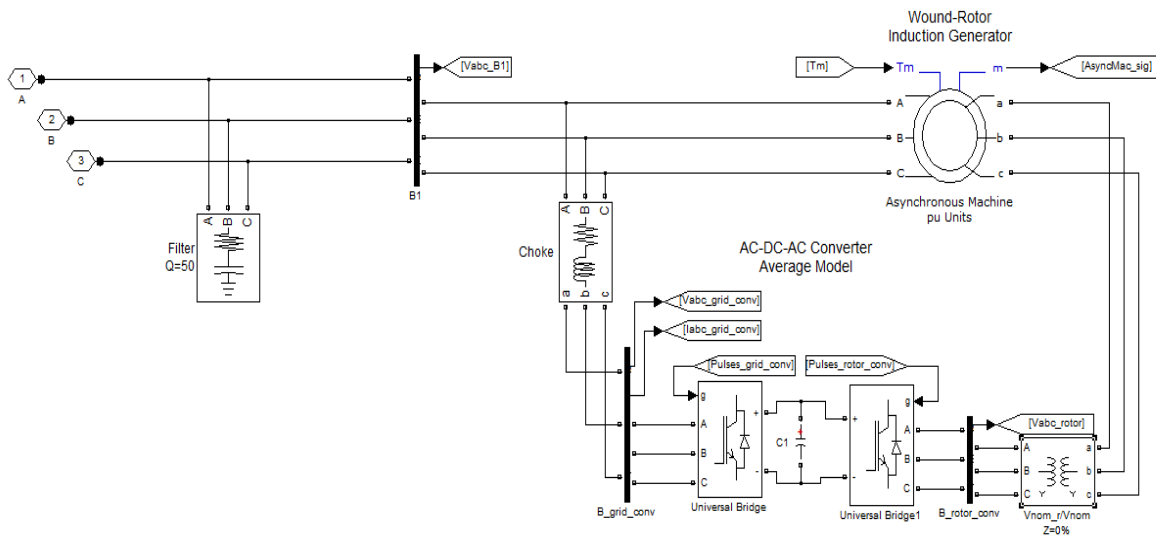

Figure_7: DC link inverter

VIII. TRANSMISSION LINE AND GRID SPECIFICATIONS

(In tabular form)

Table_1: Transmission line grid specification

Sr no	Parameter	Specification
1	3 phase programmable AC voltage	120kv,60hz
2	3 phase mutual inductance	2500MVA
3	3 phase transformer Y-Y	25kV/575V
4	3 phase pi section line	30 Km, 60Hz
5	3 phase capacitive load	

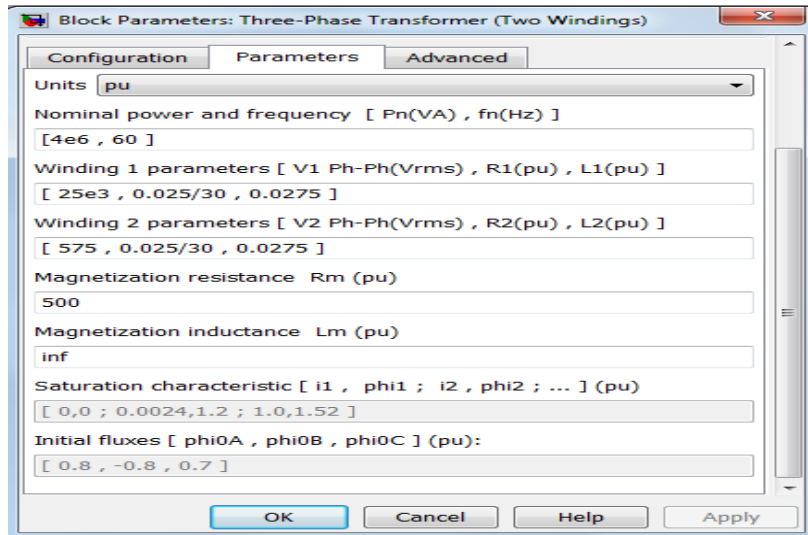

Figure _8: Three phase transformers block parameters

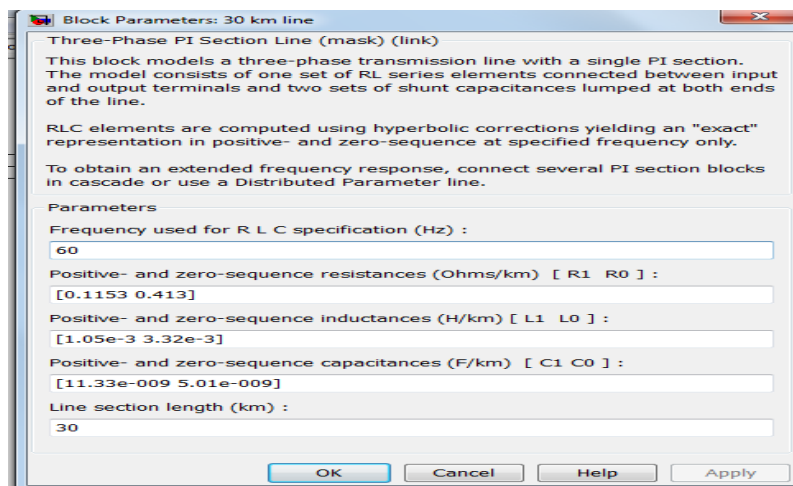

Figure _9: Transmission line parameters

IX. SIMULATION

Under normal operating condition:

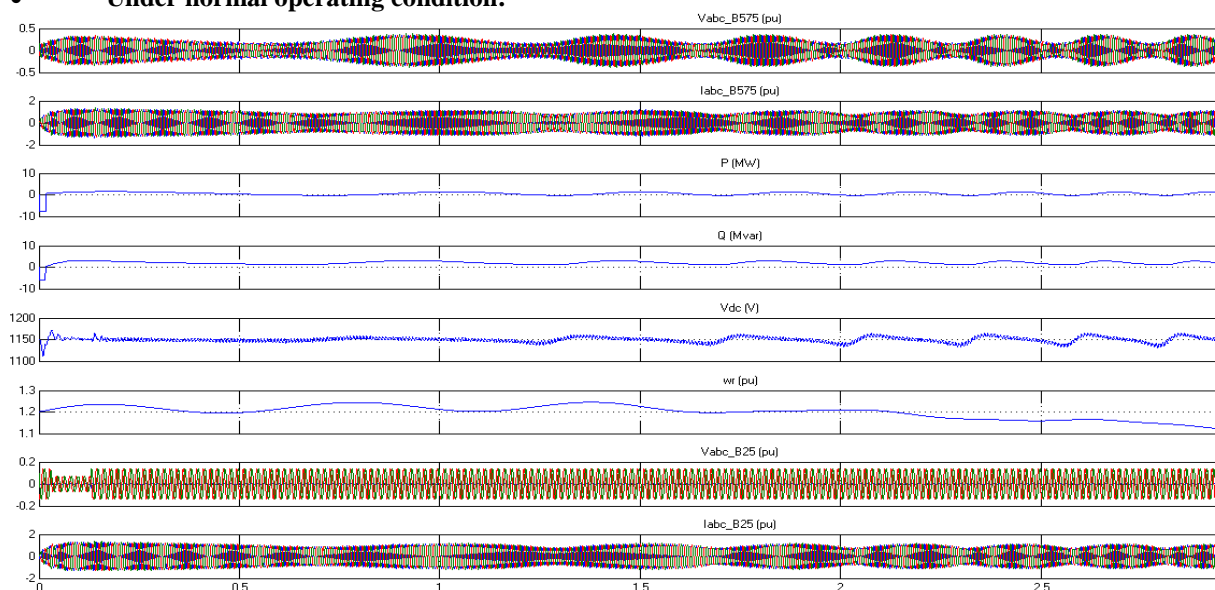
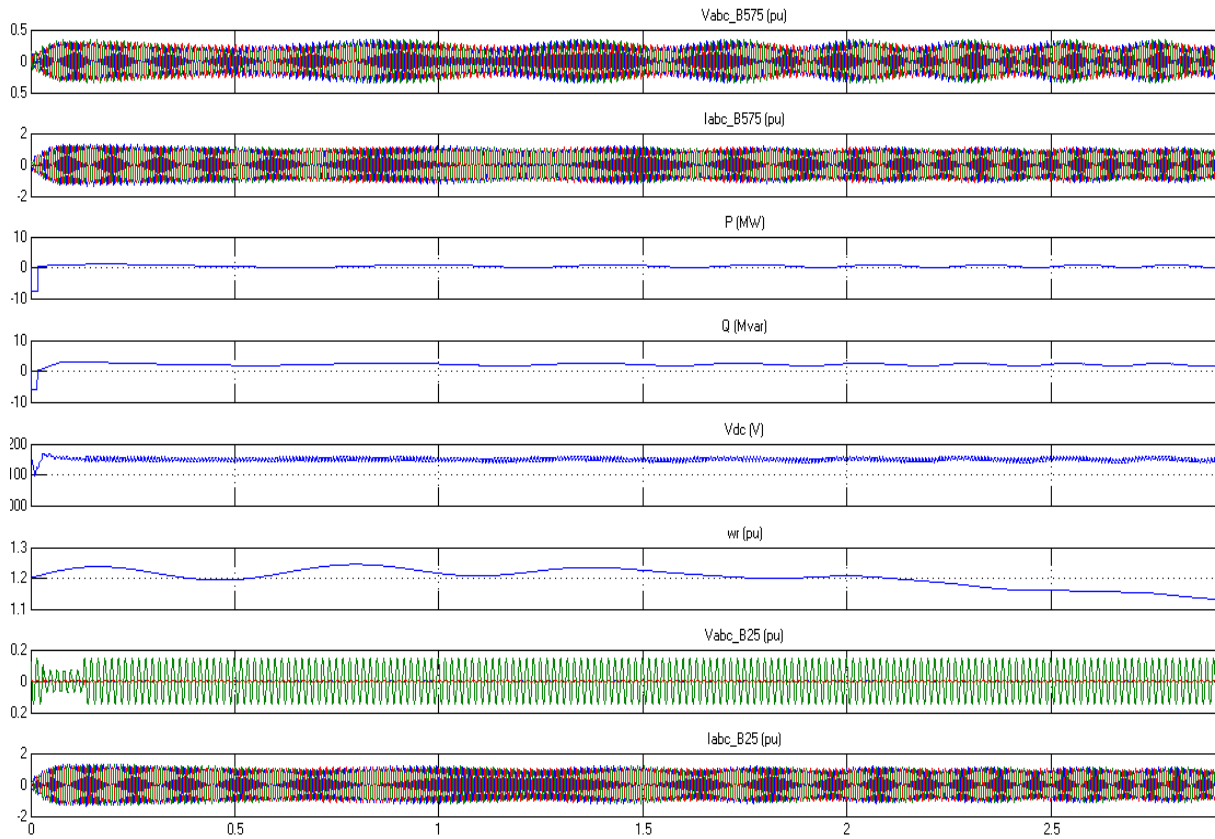

Figure _10: Output under normal operation

• **Fault conditions:**
Two phase to ground fault:



Figure_ 11: Output under two phase to ground fault

Three phase Line to ground fault:

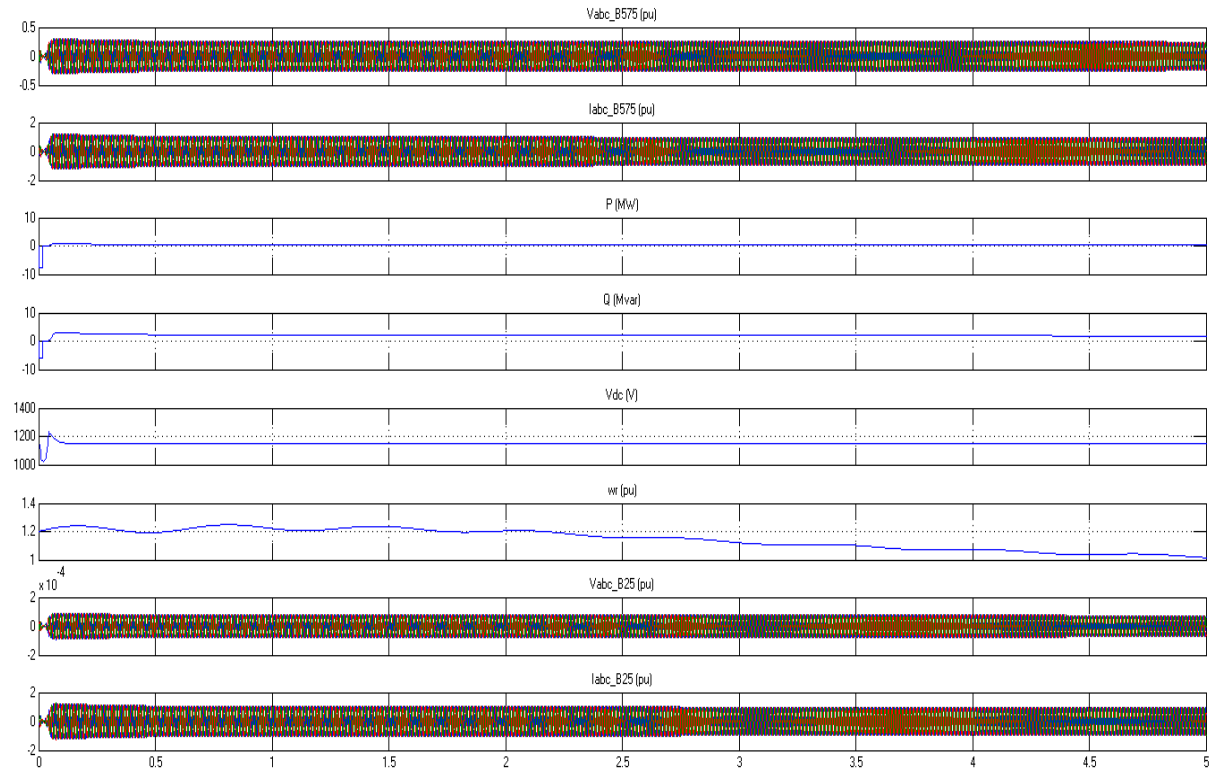

Figure_ 12: Output under three phase line to ground fault

X. SIMULATION RESULTS:

The model was simulated for the cases mentioned below:

1. Normal operating condition
2. Grid Fault Analysis
 - a. Three-Phase Line to Ground Fault
 - b. Two-Phase Line to Line Fault

The following category figures are plotted for each scenario:

1. Generator Voltage, Current, Real Power and Reactive Power
2. Generator Speed
3. Inverter Voltage, current, PWM pulses, V_{dc}
4. Grid Voltage, Current, Real Power and Reactive Power

Under normal operating condition we observe sinusoidal voltage and current waveforms for both generator and grid side. It is observed that in two phases to ground fault, the grid voltage is confined to only one phase and there are surges in active power, while the reactive power still remains constant. The inverter voltage is variable but increases to a higher value. The induction generator speed in normal operating condition remains constant whereas in both fault conditions it is declining over time. In three phases to ground fault, the inverter voltage stabilises but increases to a higher value. The real power remains close to zero in both the fault conditions.

XI. CONCLUSION AND COMMENTS:

The Matlab model created for doubly-fed induction generator based wind farm provides good results for steady state operation and fault conditions except the single-phase line to ground fault, which can be verified with help of practical data from wind farms. We have simulated different fault conditions to obtain a comparison so that these results can be used to install the necessary protective devices.

REFERENCES

- [1]. Muljadi, E.: **Pitch-controlled variable-speed wind turbine generation**; Industry Applications Conference, 1999. Thirty-Fourth IAS Annual Meeting. Conference Record of the 1999 IEEE ,Volume:1
- [2]. Liuchen Chang :**Wind Energy Conversion Systems**; IEEE Canadian Review
- [3]. Indrajit Koley, Swarnankur Ghosh, Avishek Ghose Roy, Dr.Pradip Kumar Saha , Dr.Gautam Kr. Panda :**Matlab Modelling and Simulation of Grid Connected Wind Power Generation Using Doubly Fed Induction Generator**; International Journal of Computational Engineering Research, July 2014
- [4]. Mohammed Rashid :**Power Electronics** ,Third Edition
- [5]. B.L Thereja, A.K Thereja :**Electrical Technology**, Volume 2