

## Experimental Evaluation of the Punching Shear Behavior of The Steel Grid Composite Deck

Hyun-Seop Shin<sup>1</sup>

<sup>1</sup>Structural Engineering Research Division, Korea Institute Of Civil Engineering And Building Technology, 283 Goyangdae-Ro, Ilsanseo-Gu, Goyang-Si, Gyeonggi-Do, 10223, South Korea

---

**Abstract:-** The partially filled steel grid composite deck is a composite structure made of a concrete slab disposed over a steel grid. The joint of the deck segments with regular width can be designed as mechanical connection using concrete shear keys and bolts. Since bending test was already performed to examine the structural performance of this deck system, this study focuses on its punching shear behavior. The results show that the flexural strength of the single-span deck is governed by the punching shear and that ductile behavior without sudden failure is achieved owing to the effect of the steel grid installed at the bottom of the deck. The comparison of the empirical formulae for the strength and the punching shear strength obtained from the test reveals the absence of strength loss due to the installation of the joints. Moreover, it appears also that reducing the number of the bolts by half in the connection has no significant effect on the punching shear strength.

**Keywords:-** Composite deck, Joint, Mechanical connection, Bolted concrete shear key, Punching shear

---

### I. INTRODUCTION

The partially filled steel grid composite deck shown in Fig. 1 is a composite structure made of a concrete slab disposed over a steel grid. The steel grid itself is composed of T-girders taking charge of the flexural tension and cross-bars connected perpendicularly to the T-girders. According to the adopted design method, longitudinal bars may be connected perpendicularly to the cross-bars and inserted between the T-girders to strengthen the grid structure. The composition of the steel grid with the concrete slab is achieved by means of shear keys installed at the top of the T-girders [1-6].

The joint structure that has been recently proposed for the partially filled steel grid composite deck is formed by bolted concrete shear key. This type of joint was suggested to apply the precast partially filled steel grid composite deck to horizontal supporting structures like bridges or platforms. This joint structure makes it possible to discard the separate arrangement of reinforcement or placing of filling concrete in the deck which enables to erect the whole horizontal supporting structures by assembling precast elements and achieve more economic and efficient construction [6, 7].

Bending test has been conducted previously to evaluate the structural performance of the partially filled steel grid composite deck assemblage using such mechanical joint [7-9]. The structural behavior observed in the test showed that, similarly to the other types of single-span deck, the flexural performance of the partially filled steel grid composite deck is also influenced by the punching shear.

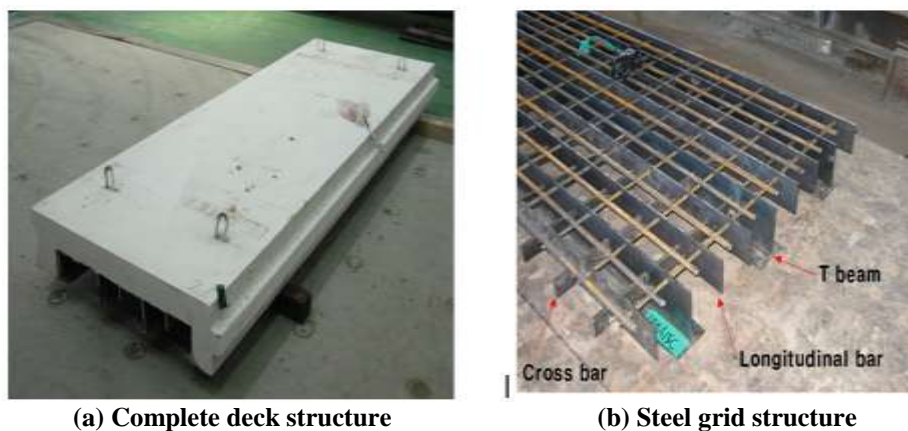

**Fig. 1:** Partially filled steel grid composite deck

Accordingly, the present paper intends to investigate the structural safety of the partially filled steel grid composite deck to punching shear and to find out if the punching shear strength of the deck is influenced by the joint realized by mechanical connection. Based on the results, this study also intends to verify the

---

applicability of the joint by mechanical connection. Therefore, the punching shear strength obtained experimentally and the shear strength calculated by empirical formulae are compared to analyze the possibility to calculate the punching shear strength of the partially filled steel grid composite deck using former empirical formulae and verify the safety of the design of the partially filled steel grid composite deck structure. Finally, the punching shear strength with respect to the number of bolts installed in the joint is examined to assess the effect of the design conditions of the joint on the change in the strength.

## II. BENDING TEST RESULTS

The present chapter summarizes the results of the bending tests performed on the partially filled steel grid composite deck prior to the evaluation of the punching shear behavior [7]. Table 1 arranges the test variables and corresponding designation of the specimens, and the structural details of the deck and joint are described in Figs. 2-4. The presence or not of joint, the number of bolts in the joint and the loading method were the test variables. Fig. 5 shows the assembling of the deck. Figs. 6 and 7 present photographs of the bending test of the deck without joint and of the deck with bolted shear key joint, respectively.

**Table 1:** List and designation of partially filled steel grid composite deck specimens [7]

Designation of specimen	Span length (mm)	Width (mm)	Joint type	Loading method	Test variables
NJD-C	2,500	2,000	–	Centric / point loading	Ref. specimen w/o joint
JD9B-C		1,000×2	Concrete shear key + 9 bolts (@300)		Number of bolts in joint
JD4B-C			Concrete shear key + 4 bolts (@600)		Number of bolts in joint
NJD-E		2,000	–	Eccentric / point loading	Ref. specimen w/o joint
JD9B-E		1,000×2	Concrete shear key + 9 bolts (@300)		Number of bolts in joint
JD4B-E			Concrete shear key + 4 bolts (@600)		Number of bolts in joint

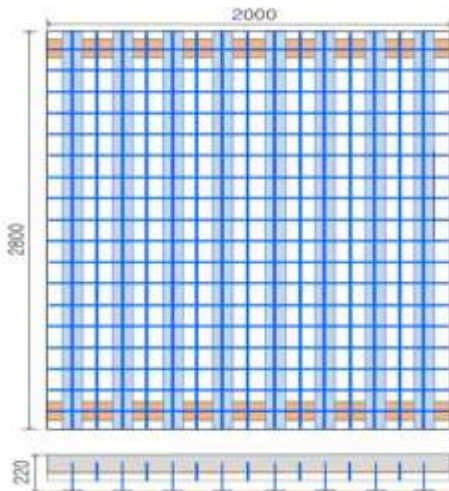

**Fig. 2:** Deck without joint (NJD) [7]

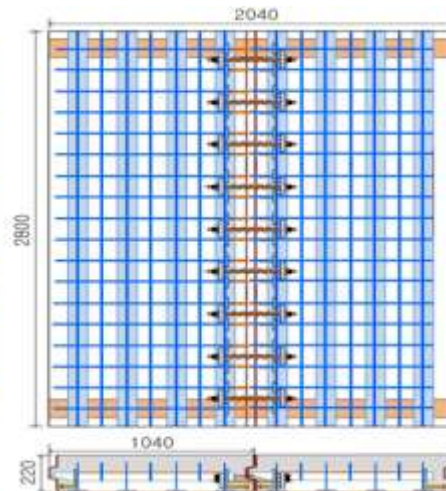

**Fig. 3:** Deck with bolted shear key joint (JD9B) [7]

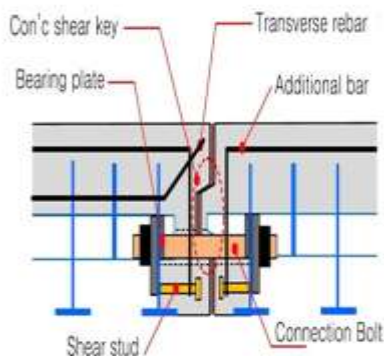

**Fig. 4:** Section details of joint [6,7]



**Fig. 5:** Assemblage of deck [7]

Table 2 summarizes the test results of the partially filled steel grid composite deck specimens [7,9]. Fig. 8 plots the load-deflection curves measured in the tests. In Table 2,  $P_y$  is the load measured at yielding of the flange of the T-girders in the deck,  $P_{f_{test}}$  is the measured punching shear strength,  $P_m$  is the measured maximum load, and  $P_{final}$  is the load measured at completion of the test. The deflection ( $\delta$ ) was measured at each loading stage. The strains  $\epsilon_{b,f}$  and  $\epsilon_{b,m}$  were measured in the bolts of the joint at punching shear strength and maximum load, respectively, and the values in Table 2 are the maxima corresponding to those of the bolt located at the center of the span.

**Table 2:** Bending test results of partially filled steel grid composite deck [7,9]

Loading method	Specimen	Yielding		Punching failure		Maximum load		Final load		Strain	
		$P_y$ (kN)	$\delta_y$ (mm)	$P_{f_{test}}$ (kN)	$\delta_{f_{test}}$ (mm)	$P_m$ (kN)	$\delta_m$ (mm)	$P_{final}$ (kN)	$\delta_{final}$ (mm)	$\epsilon_{b,f}$ ( $\times 10^{-6}$ )	$\epsilon_{b,m}$ ( $\times 10^{-6}$ )
Centric	NJD-C	600.0	13.5	875.4	31.1	875.4	31.1	862.1	55.7	-	-
	JD9B-C	750.0	20.2	975.4	40.7	994.1	52.9	978.8	72.3	1778	2069
	JD4B-C	745.0	27.7	902.8	47.2	983.1	74.8	974.8	84.9	967	8493
Eccentric	NJD-E	450.0	15.6	599.3	33.4	619.5	79.5	618.4	83.8	-	-
	JD9B-E	600.0	19.1	676.0	26.2	755.0	64.3	761.4	69.9	227	764
	JD4B-E	550.0	16.8	681.1	28.3	732.0	65.5	724.1	68.1	216	732

From the analysis of the bending test results [7,9], it appeared that, under centric loading leading to relatively larger moment in the joint, ductile behavior was achieved through the increase of the rotational angle of the joint, the yielding of the bolts and the reduction of the flexural rigidity of the joint and whole deck when the number of bolts installed in the joint was reduced from 9 to less than half, that is 4 bolts. However, the joint was seen to be governed by shear in case of eccentric loading. The bolts did not yield until the maximum load which indicated that most of the shear force was sustained by the concrete shear key. Accordingly, it could be deduced that the reduction of the number of bolts installed in the joint has no significant effect on the performance of the joint and on the whole deck structure in case of eccentric loading. In addition, compared to the centric loading, the loss of the load bearing capacity in the eccentric loading could be attributed to the difference in the effective width caused by the lateral load transfer behavior.

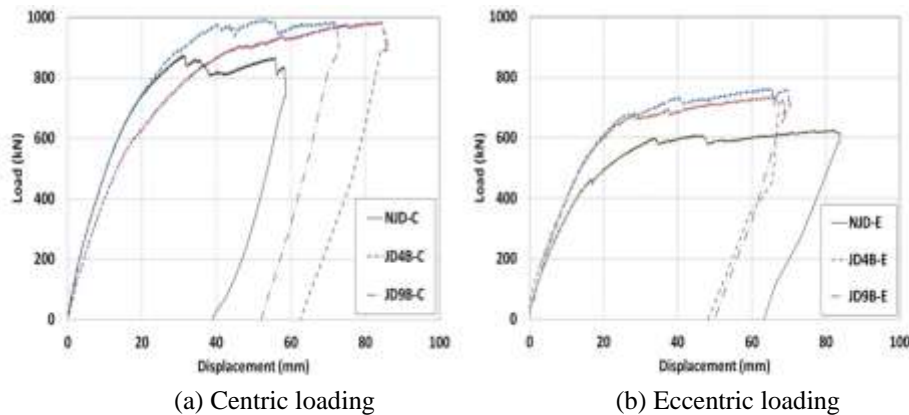

**Fig. 8:** Load-deflection curves measured in bending test of partially filled steel grid composite deck [7]

### III. ANALYSIS OF PUNCHING SHEAR BEHAVIOUR

#### A. Punching shear behaviour per specimen

##### 1) Behavior under centric loading

For specimen NJD-C, cracking oriented toward the ends of the deck occurred mainly at 790 kN around the central section of the deck. At 840 kN, punching shear cracks could be clearly observed around the loading point. Thereafter, the increase of the load by about 35 kN was accompanied with the enlargement of the crack width before the decreasing of the load. In Fig. 9(a), the punching-induced cracks can be clearly distinguished in the final crack pattern and the slight occurrence of bending-induced compressive cracks can be observed at the center of the span [7]. Accordingly, the size of the maximum load for the deck without joint appears to be sensitively influenced by the punching failure occurring at the loading position.

For specimen JD9B-C, inclined cracks developed in the deck section at about 550 kN. Beyond 780 kN, inclined cracks also developed at the top of the slab and numerous cracks occurred around the loading point with the increased load. Thereafter, the increase of the load experienced sudden reduction at 975.4 kN and increased by less than 20 kN until the completion of the test. In view of the crack pattern at the top of the slab in Fig. 10(a), numerous concentric cracks developed around the point of application of the concentrated load and

cracking also occurred along the edges of the loading plate. Moreover, compressive cracks can be clearly distinguished all over the width at mid-span [7]. Consequently, punching failure occurred but the deck could preserve flexural performance to a certain extent enabling the occurrence of clear compressive cracks over most of the slab width.

For specimen JD4B-C and in view of its crack pattern in the loading range running from 394 kN to 756 kN, inclined cracks occurred in the section and sides of the slab, and concentric cracks developed around the loading point at the top of the slab. At 800 kN and 850 kN, cracking developed in parallel to the loading plate at both left and right-hand sides of the loaded point. Then, beyond 900 kN, the load did not experience significant change and increased with a smooth slope [7].

Compressive cracks appeared clearly at the top and sides of the slab in specimen JD9B-C whereas such cracking could not be clearly distinguished in specimen JD4B-C (Fig. 11(a)). Moreover, in view of the load-deflection curves, there is a portion where the load did not increase but without sudden reduction of the load. This phenomenon can be assumed as one reason for the higher ductility shown by specimen JD4B-C presenting a deficiency in the flexural rigidity due to the relatively smaller number of connecting bolts in the joint as compared to specimen JD9B-C.

## 2) Behavior under eccentric loading

For specimen NJD-E, inclined cracks appeared in the section and top of the slab at 517 kN and 540 kN. At 535 kN, compression-induced cracks occurred on the sides of the slab at proximity of the loaded point, and failure cracking pattern could be clearly observed at 595 kN (Fig. 9(b)). Later, the load experienced temporary decrease at 599.3 kN to show very slight increase after that point [7]. Compared to specimen NJD-C, punching cracks could not be clearly observed on the perimeter of the loading plate but, in view of the concentric cracks developed at the top of the slab, it can be concluded that punching shear has determinant effect on the size of the maximum load.



(a) Centric loading



(b) Eccentric loading

**Fig. 9:** Deck without joint (specimen NJD) [7]



(a) Centric loading



(b) Eccentric loading

**Fig. 10:** Deck with 9 bolted shear key joint (specimen JD9B) [7]

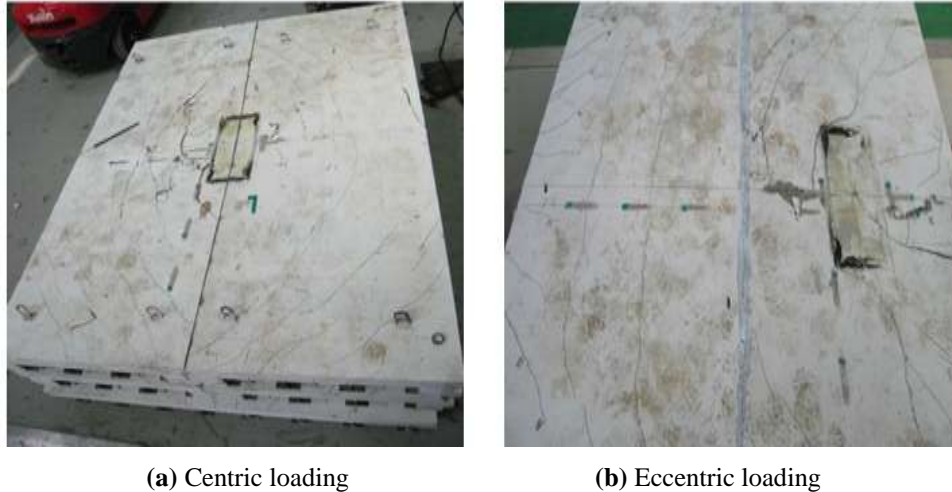

**Fig. 11:** Deck with 4 bolted shear key joint (JD4B) [7]

For specimen JD9B-E, the cracking pattern occurring between 365 and 600 kN shown in Fig. 10(b) reveals the occurrence of inclined cracks propagating from the slab section to the top and numerous punching shear cracks developing concentrically around the loading point. Compressive cracks appeared at 648 kN and propagated gradually over the whole width of one deck. However, these compressive cracks did not occur in the deck that was not directly subject to the load. At 676 kN and 733 kN, sudden loss of the load occurred due to punching shear and, beyond 733 kN, the load experienced small increase [7]. Compared to specimen JD9B-C, the punching shear cracks show U-shapes rather than closed polygons around the loading plate, and punching failure occurred earlier in the case of eccentric loading.

For specimen JD4B-E, the cracking pattern caused by the punching shear between 275 kN and 680 kN is similar to that of specimen JD9B-E. At 668 kN, compressive cracks developed on the sides and top of the slab, which is also similar to specimen JD9B-E (Fig. 11(b)). At 681.1 kN and 693.5 kN, the load experienced sudden loss due to punching shear and increased by a small amount beyond 693.5 kN [7]. The overall behavior and failure pattern are practically similar to those of specimen JD9B-E.

### B. Comparative analysis of punching shear strength

In the case of the single-span deck, the strength design method can be applied assuming the deck as beam of unit width. However, the maximum load under the application of a concentrated load is determined by the punching shear rather than bending. To confirm this fact, recall that the bending test of the deck performed previously [7] also verified that most of the specimens were significantly influenced by the punching shear. Accordingly, the strength obtained from the test is compared to the strength calculated from empirical formulae to evaluate the change in the structural behavior and punching shear strength with respect to the joint conditions.

In view of the cracking pattern of the specimens and in case of centric loading, numerous elliptic cracks developed around the loading plate and rectangular punching shear cracks occurred clearly at proximity of the loading plate. In case of eccentric loading, perfectly concentric cracks did not occur due to the difference in the resistance of the deck according to the position of the load, and the shape of the punching shear cracks around the loading plate exhibited U-shape rather than being closed.

Based upon such observation, it seems acceptable to conclude that the critical section induced by punching shear under centric loading takes the shape of a closed rectangle and that under eccentric loading a U-shape enclosing the loading plate. These shapes of the critical section agree with those of previous design theories for the punching shear [10].

ACI 318-05 specifies to compute the punching shear strength by selecting the smallest value among those given by the following formulae for the two-way punching shear. Here,  $\alpha_s$  is a coefficient related to the position of the ground plane (= 40 for interior, = 30 for edge, = 20 for corner);  $b_0$  is the perimeter of the critical section; and,  $d$  is the effective depth [10].

$$V_c = 0.083 \left( 2 + \frac{4}{\beta_c} \right) \sqrt{f_{ck}} b_0 d \quad (1)$$

$$V_c = 0.083 \left( 2 + \frac{\alpha_s d}{\beta_c} \right) \sqrt{f_{ck}} b_0 d \quad (2)$$

$$V_c = 0.083 \times 4 \sqrt{f_{ck}} b_0 d \quad (3)$$

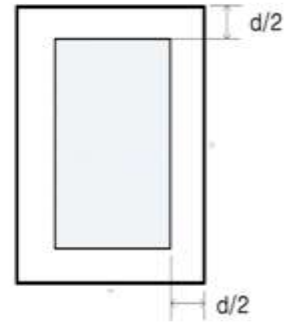

(a) Punching shear pattern around the loading plate (b) Method for determining the critical section

**Fig. 12:** Critical section for punching shear under centric loading

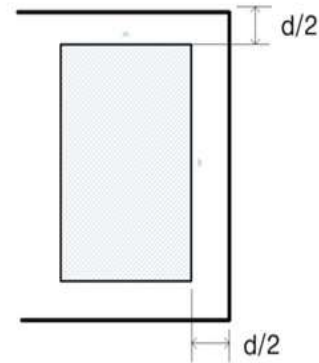

(a) Punching shear pattern around the loading plate (b) Method for determining the critical section

**Fig. 13:** Critical section for punching shear under eccentric loading

In general, the shear strength  $V_c$  of concrete is assumed to be equal to the nominal shear strength  $V_n$ . However, when strengthening is done using stirrups or studs, the nominal shear strength  $V_n$  becomes

$$V_n = V_c + V_s = \frac{1}{6} \sqrt{f_{ck}} b_0 d + V_s \leq \frac{1}{2} \sqrt{f_{ck}} b_0 d \quad (4)$$

For the partially filled steel grid composite deck, the steel grid at the bottom of the slab applies as the structure resisting to punching shear. Referring to a previous work related to the partially filled steel grid composite deck [2], the punching shear strength applies the formula  $0.5\sqrt{f_{ck}} b_0 d$ . Table 3 compares the punching shear strength computed for each specimen and that obtained experimentally. The comparison of the calculated and experimental punching shear strengths under centric loading shows that the experimental value is larger than the calculated one by 1.47 times for the deck without joint, and by 1.63 times and 1.51 times for the specimens with joint JD9B-C and JD4B-C, respectively. The same comparison for the eccentric loading reveals that the experimental value is larger than the calculated one by 1.51 times for NJD-E, the specimen without joint, and by 1.71 times and 1.72 times for the specimens with joint JD9B-E and JD4B-E, respectively. Compared to the centric loading, the smaller punching shear strength developed under eccentric loading can be attributed to the difference in the perimeter of the critical section ( $b_0$ ) and the slab section height ( $d$ ) at the critical section.

In view of the comparison of the experimental and calculated punching shear strengths, there is no loss of the strength caused by the installation of the joint. Moreover, the comparison of the strengths of the specimens with different number of bolts in the joint shows that there is no significant loss of the strength even when the number of bolts is reduced from 9 to 4. The occurrence of the slight difference according to the number of bolts in case of centric loading can be explained by the difference in the lateral flexural rigidity with respect to the connecting condition of the joint.

**Table 3:** Comparison of punching shear strength for the partially filled steel grid composite deck

Loading method	Specimen	Experimental maximum load $P_m$ (kN)	Experimental punching shear $P_{f, test}$ (kN)	Calculated punching shear $V_{an}$ (kN)	$P_m/V_n$	$P_{f, test}/V_n$
Centric	NJD-C	875.4 (1.00)	875.4 (1.00)	597.5	1.47	1.47
	JD9B-C	994.1 (1.14)	975.4 (1.11)		1.66	1.63
	JD4B-C	983.1 (1.12)	902.8 (1.03)		1.65	1.51
Eccentric	NJD-E	619.5 (1.00)	599.3 (1.00)	396.4	1.56	1.51
	JD9B-E	755.0 (1.22)	676.0 (1.13)		1.90	1.71
	JD4B-E	732.0 (1.18)	681.1 (1.14)		1.85	1.72

#### IV. CONCLUSIONS

In the case of decks presenting large sectional height, most of the final failures are induced by the punching shear. This is the reason why the load applied up to this point is assumed as the actual maximum load. The comparison of the experimental punching shear strength and that calculated from empirical formulae revealed that, even if the flexural rigidity of the deck decreased due to the reduction of the number of bolts installed in the joint, this reduction did not affect significantly the load bearing capacity of the deck. Based on this observation, the adequate design of the joint of the partially filled steel grid composite deck assemblage will undoubtedly achieve structural performance at least equivalent to that of the deck without joint.

Moreover, the analysis of the overall behavior based on the experimental data showed that, in most cases, the occurrence of punching failure was accompanied with loss of the load. However, the deck specimens could preserve load bearing capacity to a certain extent until completion of the tests even after the occurrence of punching shear. Based upon this observation, the partially filled steel grid composite deck appeared to achieve ductile behavior without risk of sudden collapse caused by the brittle failure even under the occurrence of punching shear. This behavior could be explained by the effect of the plastic deformability of the steel grid installed at the bottom of the slab.

#### REFERENCES

- [1]. C.J. Earls, T.R. Johnston, "Behavior of Field Splice Details in Precast Concrete-Filled Steel Grid Bridge Deck", Journal of Bridge Engineering, Vol.9, pp.127-136, 2004.
- [2]. C. Higgins, H. Mitchell, "Behavior of Composite Bridge Decks with Alternative Shear Connectors", Journal of Bridge Engineering, Vol.6, pp.17-22, 2001.
- [3]. H. Huang, M.J. Chajes, D.R. Mertz, Shenton, H.W., Kaliakin, V.N., "Strength behavior of filled steel grid decks for bridges", Bridge Structure, Vol.3, no.2, pp.105-118, 2007.
- [4]. M. J. Pierce, Evaluative testing of a novel weldless open steel grid deck system. Master's thesis. Pittsburgh University, pp.1-33, 2005.
- [5]. J. Versace, J. Ramirez, Implementation of full- width bridge deck panels; A synthesis study. FHWA /IN/JTRP-2003/24: Purdue University, pp.1-66, 2004.
- [6]. H.S. Shin, "An Investigation of the Shear Design of Bolted Shear Key Joint in Partially Filled Steel Composite Decking System", International Journal of Engineering Research and Development, Vol.12, Issue 7, pp.1-9, 2016.
- [7]. Korea Institute of Civil Engineering and Building Technology, Development of High Performance Material & Rapid Construction Technology for Extreme Environment. Annual Report: KICT, 2013 (in Korean).
- [8]. H.S. Shin, K.T. Park, "Shear Resistance Evaluation of Steel Grid Composite Deck Joint", Journal of the Korea Academia-Industrial Cooperation Society, Vol.14, no.10, pp.5290-5298, 2013 (in Korean).
- [9]. H.S. Shin, "Experimental Study on the Load Transfer Behavior of Steel Grid Composite Deck Joint," Journal of the Korea Institute for Structural Maintenance and Inspection, Vol.18, no.4, pp.10-21, 2014 (in Korean).
- [10]. ACI Committee 318, Building Code Requirements for Structural Concrete (ACI 318-05) and Commentary (ACI 318R-05), American Concrete Institute, Farmington Hills, Michigan, USA, 2005.