

Power Flow Control between Two Transmission lines by Capacitive Reactance

K.Bhanu Kiran¹, Dr.M.Ramkumar Prabhu².

¹Research Student, Bharath University, Chennai.

²Professor, Apollo Priyadarshanam Institute of Technology, Chennai.

Corresponding Author: K.Bhanu Kiran

ABSTRACT: Solid state power electronic devices or Flexible AC Transmission Systems technologies has brought an scope for electric utilities to operate their bulk power flow network close to their thermal limits while maintaining and/or improving network security or reliability. High-power electronic devices can provide unprecedented control over electricity flow in transmission networks. These devices responds quickly enough to changing network conditions to provide real-time power flow control, which is essential when large numbers of power transactions occur in a fully deregulated electric industry. In this paper a MATLAB / SIMULINK model of Electronic Controller has been developed for quick power flow control between two Areas connected by two transmission lines. This is achieved by increasing /decreasing its capacitive reactance online. The TCSC also helps in limiting and damping the angular/frequency swings caused by the disturbances. The simulations are carried out using MATLAB/SIMULINK.

INDEX TERMS: Flexible AC Transmission Systems (FACTS), power system stability, Thyristor Controlled Series Capacitor (TCSC).

Date of Submission: 20 -01-2018

Date of acceptance: 12-02 2018

I. INTRODUCTION

Power electronic based controllers like generator excitation systems, SVC, TCSC and DC links allow real and reactive power flow control. Flexible AC Transmission Systems controllers are used to control various power system problems. Power oscillation damping, Reactive power compensation, bus-voltage control, enhancement of power transfer are some of the major applications [1-9]. The Flexible AC Transmission Systems technology has already proved itself to be superior over the switched capacitor or reactor blocks due to fast response time and extended range of operation. These devices employ control circuitry for controlling the conduction range of power converters so as to control either the DC bus voltage and/or controlling the reactive power fed to the power system. The series compensation is an economic method of improving power transmission capability of the lines [10-12]. One of the promising Series FACTs device is the thyristor controlled series capacitor (TCSC). It is able to control the power flow, provide damping to the inter-area and local mode oscillations, and improve transient stability. In this paper, one such application of the TCSC using its simplified MATLAB/SIMULINK model is demonstrated. This paper is organized as follows. First; system modeling and proposed TCSC structure is explained in section II, Next section III shows the simulation studies and the effectiveness of TCSC has been validated on two area two machine system in different conditions, the conclusion is given in section IV.

II. POWER SYSTEM MODELING

Considering a power system having two synchronous Generators as shown in the Fig.1. A series controlled device (TCSC) is placed in one of the parallel lines. The lines have unequal impedance. Therefore steady state power flow through them is not equal.

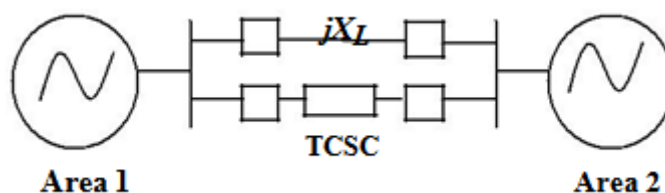

Fig. 1 Two Machine System with TCSC Controller

2.1 Generators

The Generator is represented by its classical model comprising of the electromechanical swing equation. Assuming transient voltage of generator and the input mechanical power are constant, the two machine system with TCSC can be described using following non linear equations:

$$\dot{\delta} = \omega_b (\omega - 1) \quad (1)$$

$$\dot{\omega} = [P_m - P_e - D (\omega - 1)] / M \quad (2)$$

Where P_m and P_e are the input and output powers of the synchronous generator, respectively; D and M are the damping coefficient and inertia constant, respectively; ω_b the synchronous speed; ω and δ are the speed and rotor angle respectively.

2.2 TCSC structure

The basic circuit of TCSC is shown in Fig.2 with resistances have been neglected. The TCSC consists of a capacitor C connected in a parallel thyristor-controlled inductor L . The firing angle (α) of the thyristors is controlled to adjust the TCSC reactance (X_{TCSC}) in response to system parameter variations. TCSC operates such that the TCSC is seen by the circuit as, virtually, having an increased reactance beyond the original reactance of the of TCSC capacitor, i.e., the TCSC is seen as controllable equivalent reactance.

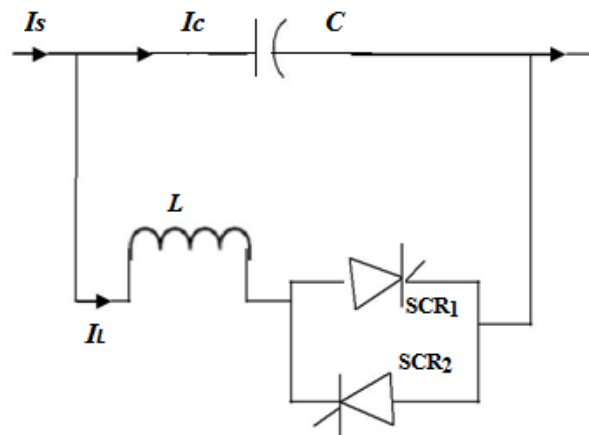

Fig. 2 Basic Module of TCSC

There exists a relationship [13] between firing angle (α) and the TCSC reactance (X_{TCSC}). This relationship is described by the following equation.

$$X_{TCSC} = X_C - \frac{X_C^2}{(X_C - X_p) \pi} \frac{2\beta + \sin 2\beta + 4X_C^2}{(X_C - X_p) (k^2 - 1)} \frac{\cos^2 \beta}{\pi} (k \tan k\beta - \tan \beta)$$

Where X_C = Nominal Reactance of the fixed Capacitor X_p = Reactance of Inductor L

$K = (X_C / X_p)^{1/2}$ = Compensation Ratio

$\beta = \pi - \alpha$ = conduction angle of TCSC controller

The relationship between firing angle and the TCSC reactance is a unique valued function therefore TCSC is modeled as a variable capacitive reactance. The TCSC is used in capacitive zone. Fig. 3 shows the resonance. For the inductive region, which is not used in steady state, acceptable values of the firing angle are between 90° and α_{maxL} , where $\alpha_{maxL} < 90^\circ$, with the resonant value of

firing angle being determined by the ratio X_C / X_L . The capacitive region is limited by 180° and α_{minC} .

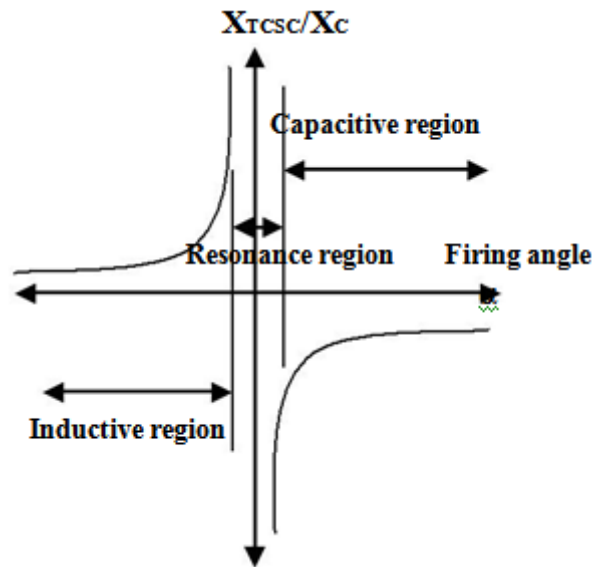

Fig. 3 X_{Tcsc} / X_c Vs FIRING ANGLE (α) CURVE

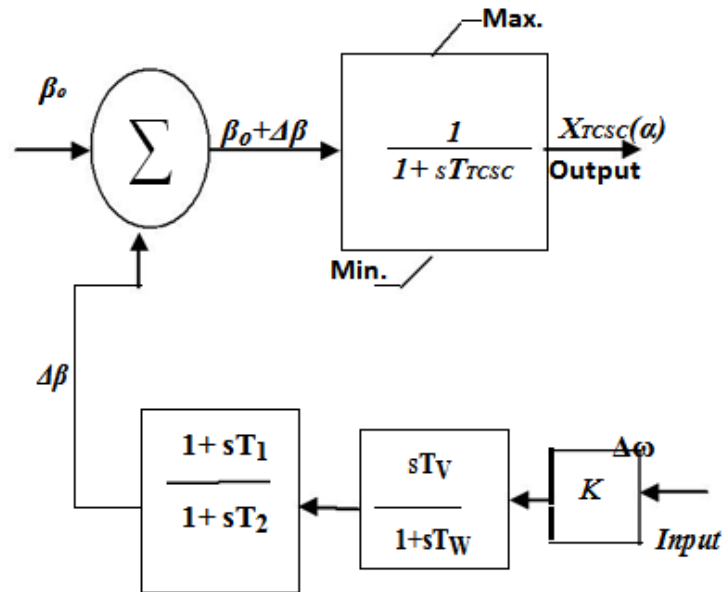

Fig. 4 Structure of TCSC Controller

The structure of TCSC controller, to modulate the reactance [14-19] offered by the TCSC is shown in Fig. 4. TCSC controller input signal $\Delta\omega$ is speed deviation and the signal $\Delta\beta$ is deviation in conduction angle. It consists of gain block, washout block and compensator block. An optimum controller can be obtained by proper tuning of parameters T_w , T_1 , T_2 and gain K with a suitable heuristic technique. The gain K of TCSC controller is chosen such that it provides necessary damping. The phase compensator block is used to reduce the angular difference as well as to make the system "settle down" quickly. The output of the controller has to be gradually driven to zero in steady state. Therefore a washout transfer function $[5s/(5s+1)]$, which has a steady state gain zero is used. The value of wash out time constant T_w , may be in the range of 1-20 sec.

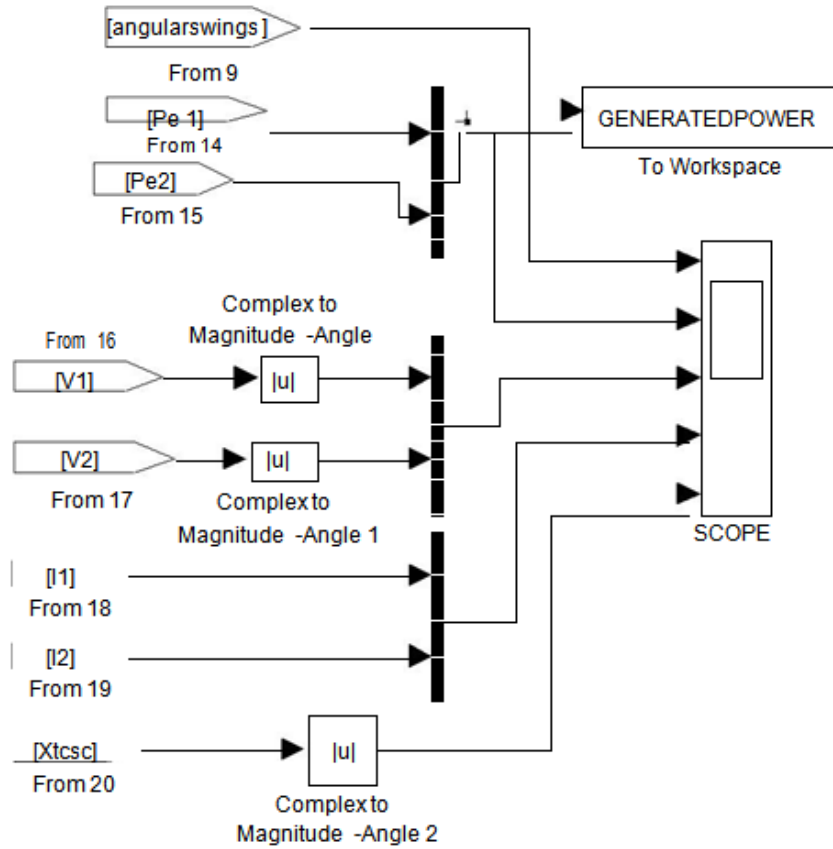

Fig.5(a)

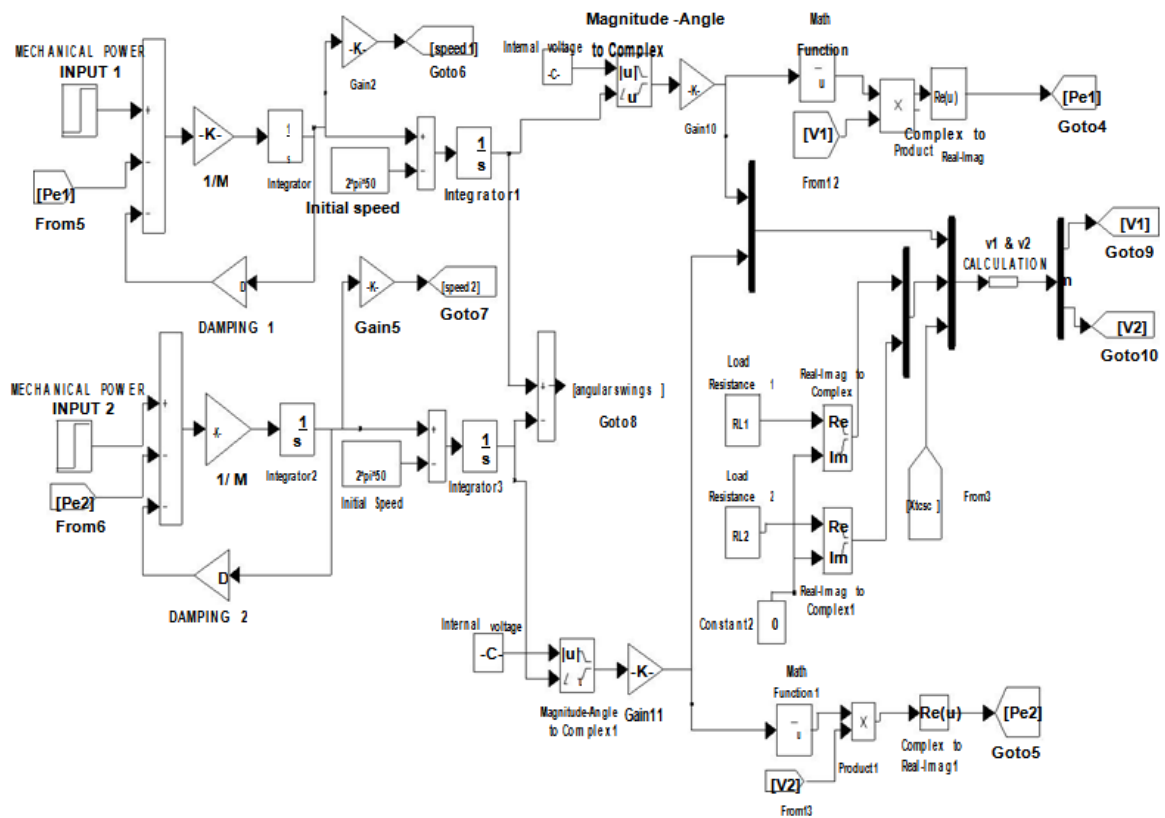

Fig.5(b)

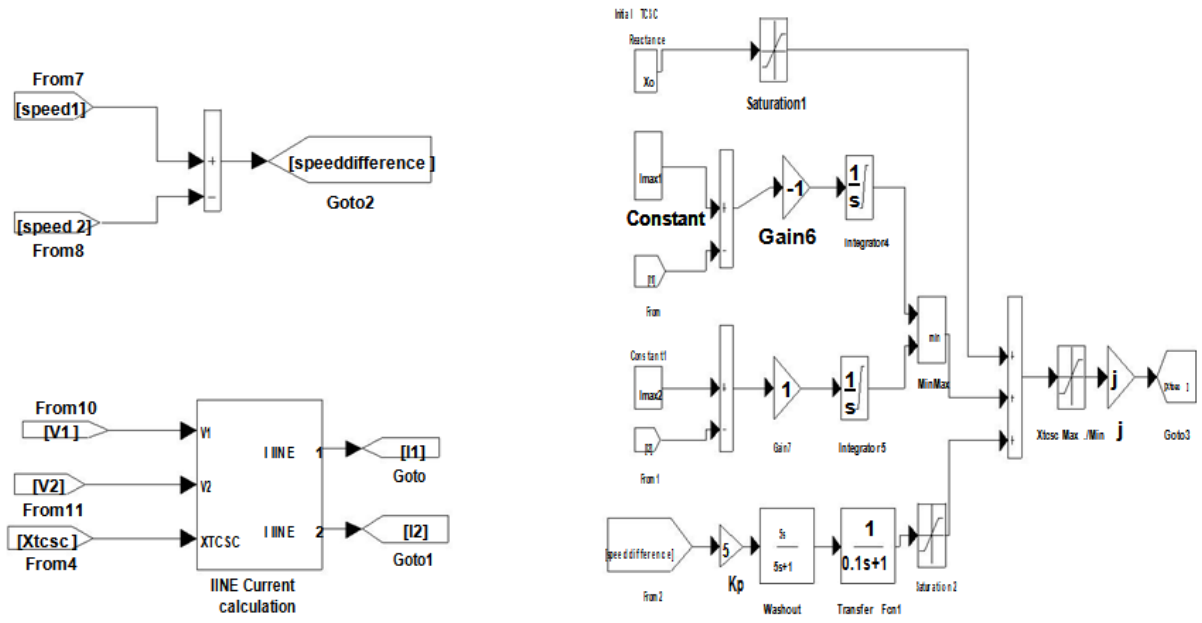

Fig.5(c)

Fig. 5 (a) – (c) Simulink Model of Two-Area System with TCSC controller

The MATLAB/SIMULINK model of the power system shown in Fig.

1 is developed using equations (1)–(2). The developed MATLAB/SIMULINK model of synchronous generators with TCSC is shown in Fig. 5. The system parameters are given in appendix.

III. SIMULATION STUDIES

The Power system shown in figure 1 is studied through the computer simulation using the MATLAB/Simulink in MATLAB environment. To illustrate the efficiency of the TCSC controller, two different cases are presented; with and without controller. Fig. 6(a)-(d) and Fig. 7(a)-(d) shows the system response with respect to time for the two cases.

3.1 System with TCSC Damping Controller

Fig. 6 shows the system response with TCSC when damping controller is enabled. A small disturbance in mechanical power

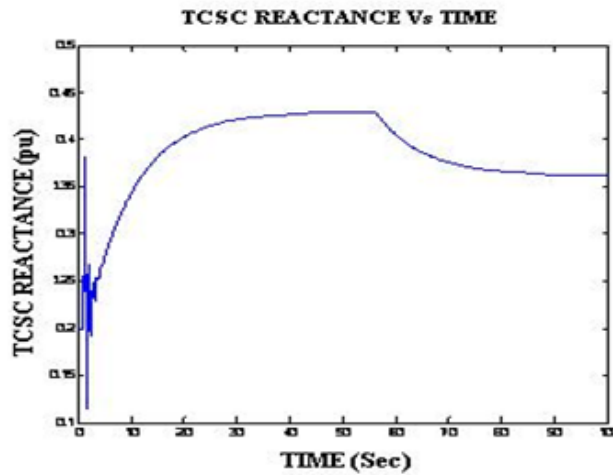

(a)

Fig.6(a) System response for a 5% increase (decrease) in Mechanical power of Generator 1(Generator 2)-TCSC Reactance

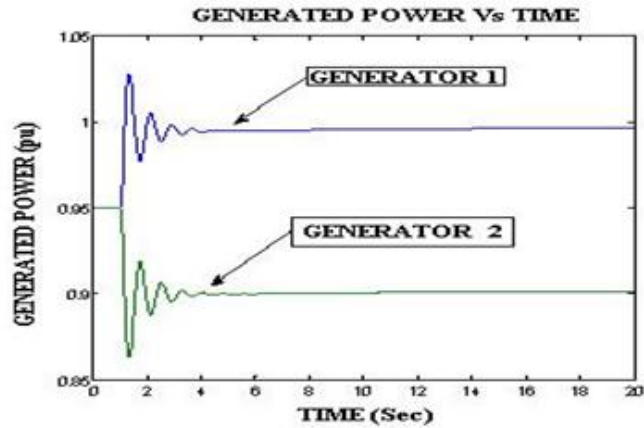

(b)

Fig.6(b) System response for a 5% increase (decrease) in Mechanical power of Generator 1(Generator 2)-Generated Power

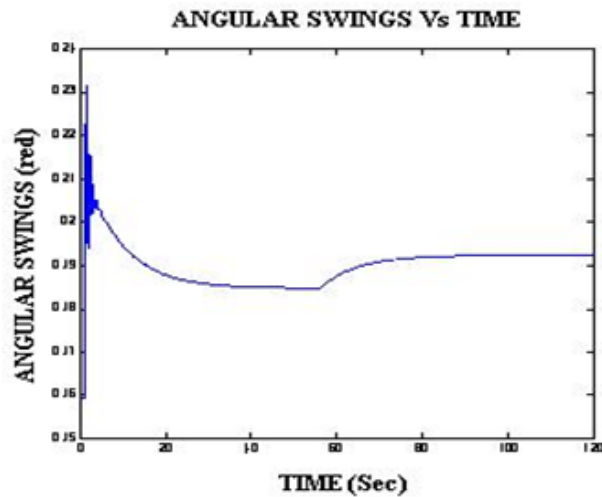

(c)

Fig.6(c) System response for a 5% increase (decrease) in Mechanical power of Generator 1(Generator 2)-Angular Swings

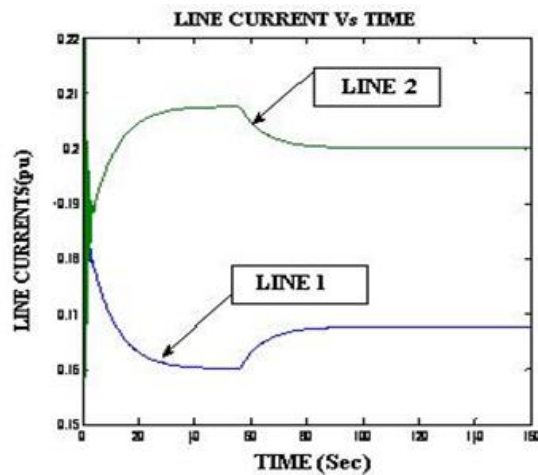

(d)

Fig.6(d) System response for a 5% increase (decrease) in Mechanical power of Generator 1(Generator 2)-Line Currents

input is considered. At $t=0$ sec, the input mechanical power is increased by 5% in Generator 1 and decreased by 5% in Generator 2. It can be seen that Generation by alternator in Area 1 is increased and Generation by alternator in Area 2 is decreased by the same amount. This cause increased power flow through the two lines thereby overloading one of the lines. The TCSC quickly diverts the power flow by increasing its capacitive reactance. The TCSC also helps in limiting and damping the angular/frequency swings caused by the load disturbances.

3.2 System without TCSC Damping Controller

Fig. 7 (a)-(d) shows the system response with TCSC when damping controller is disabled. It can be seen that due to disabling of damping Controller in TCSC model there are substantial oscillations in the system but these oscillations are controlled by TCSC [Fig. 6(a)-(d)] damping controller. The TCSC controller provides a very fast action to increase the power flow through quick changing of the equivalent capacitive reactance to the full compensation in the first few cycles after the disturbance, hence subsequent oscillations are well damped out.

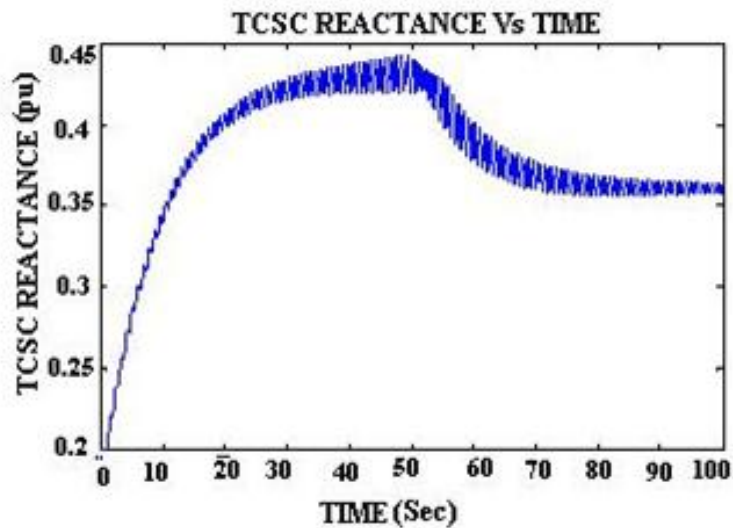
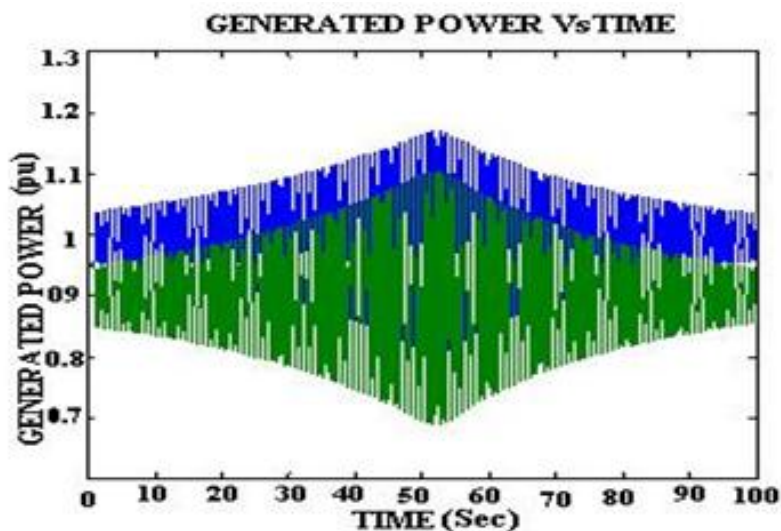
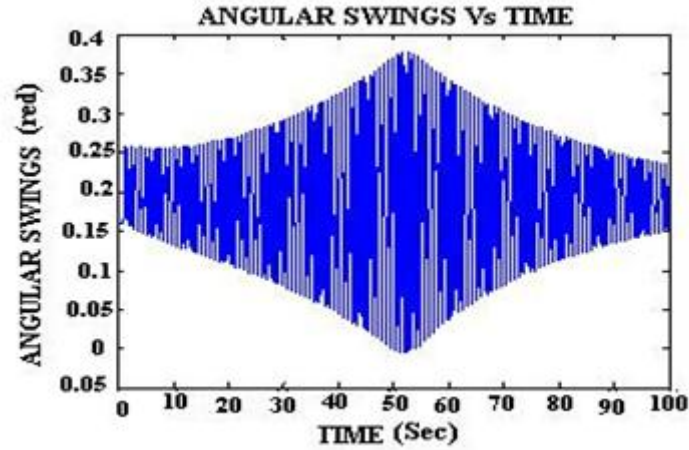

Fig.7(a) System Response for 2-Machine System with TCSC without damping Controller-TCSC reactance



(b)

Fig.7(b) System Response for 2-Machine System with TCSC without damping Controller -Generated Powers



(C)

Fig.7(c) System Response for 2-Machine System with TCSC without damping Controller - Angular Swings

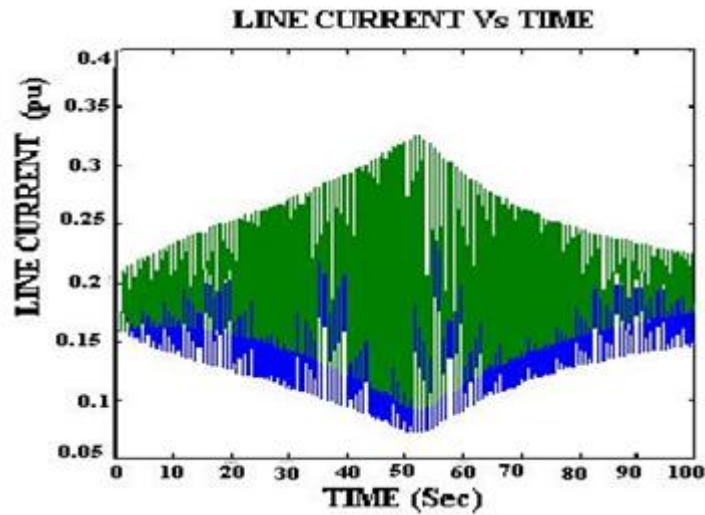

(d)

Fig.7 (d) System Response for 2-Machine System with TCSC without damping Controller-Line Currents

IV. CONCLUSION

The MATLAB/SIMULINK model of TCSC for Two Area Power Flow Control presented in the paper provides a means for carrying out power system analysis and for explaining the generator dynamic behavior as affected by the TCSC. The simulation results show the robustness and superiority of the proposed control, and indicate that the controller can automatically decides the compensation, effectively maintain transient stability and greatly improve dynamic performance of power system. It has been observed from the Fig. 6(a)-(d) and Fig. 7(a)-(d) that the system without TCSC controller is unstable but with TCSC controller the system gains stability. The system attains stability at a faster rate due to series compensation provided by TCSC controller. Further it is observed that the proposed TCSC controller is effective in damping low frequency oscillations resulting from small disturbances conditions because of increase or decrease in mechanical power input.

V. APPENDIX

Generator: $H=6$, $D=0.0$
 Transmission Line: $X1=1.0$, $X2=1.2$
 TCSC Controller: $Xo=0.2$, $Xmax=0.5$, $Xmin=0.1$, $Tw=5Sec$, $T1=0$,
 $T2=0.1Sec$

REFERENCES

- [1]. Wang, H.F , “Phillips-Heffron model of power systems installed with STATCOM and applications” *Generation, Transmission and Distribution IEE Proceedings* Volume 146, Issue 5, Pages: 521-527, 1999
- [2]. Wang, H.F, “Modeling multiple FACTS devices into multi-machine power systems and applications” *Electrical power & Energy systems*, vol.25, pp.227- 237,2003
- [3]. D.Shen and P.W.Lehn, “Modeling, Analysis, and Control of a Current Source inverter-based STATCOM,” *IEEE Transactions on Power Delivery*, Vol .17, No.1, pp.248- 253, 2002
- [4]. A.M.Kulkarni,K.R.Padiyar,“Damping of power swings using series facts controllers,” *Electrical Power and Energy systems*, vol.21, pp.475-495, 1999.
- [5]. N.Tambey, M.L.Kothari, “Damping of power system oscillations with UPFC,”*IEE Proc.Trans. Distrib.* Vol. 150, March 2003.
- [6]. N.Tambey, M.L.Kothari, “UPFC based Damping Controllers for Damping Low Frequency oscillations in a Power System,” *IEE Proc. Trans.Distrib.*Vol. 84, June 2003.
- [7]. G.Radman, R.S.Raje, “Dynamic model for power systems with multiple FACTS Controller,” *Electrical Power system Research* vol.78, issue3, Pages 361-371, 2008.
- [8]. K.K.Sen, “Static Synchronous Series Compensator: Theory, Modeling and Application,” *IEEE Trans. on Power Delivery*, 13 (1), pp. 241- 246, 1998.
- [9]. S.H Kim, J.U.Lim, and S.Moon,“Enhancement of Power System Security Level through the Power Control of UPFC,” *IEEE Con*, pp. 38-43, 2000.
- [10]. N. G. Hingorani and L. Gyugyi, “*Understanding FACTS Concepts and Technology of Flexible AC Transmission Systems*”, IEEE Press. New York, 1999. Arthur R. Bergen Vijay Vittal, “Power System Analysis”, Second Edition, Pearson Education Asia, pp 528-529.
- [11]. Lennart Angquist, Gunnar Ingestrom, Hans-Ake Jonsson, “Dynamical Performance of TCSC Schemes”, *CIGRE-2006 14:302*, ABB power system.
- [12]. R. M. Mathur and R.K. Varma, “*Thyristor based FACTS controllers for Electrical Transmission Systems*”, IEEE press, Piscataway, 2002.
- [13]. X. Zhou, J. Liang, "Overview of control Schemes for TCSC to Enhance the Stability of Power System", *IEEE proceedings of transmission and distribution*, Vol. 146, No. 2, March 1999, pp.125 - 130.
- [14]. J. J. Paserba, N. W. Miller, E. V. Larsen, R. J. Piwko, "A Thyristor Controlled Series Compensation Model for Power System Stability Analysis", *IEEE Transaction on Power Delivery*, Vol. 10, No. 3, July 1995, pp. 1471 - 1478.
- [15]. K. R. Padiyar, Uma. Rao, "Discrete Control of Series Compensation for Stability Improvement in Power Systems", *Electrical Power and Energy Systems* 1997, Vol. 19, No. 5, pp.311-319.
- [16]. M. Noroozian, L. Angquist, M. Gandhari, G. Andersson, "Improving Power System Dynamics by Series Connected FACTS devices", *IEEE Transaction on Power Delivery*, Vol. 12, No. 4, Oct. 1997, pp. 1635 - 1641.
- [17]. B. H. Li, Q. H. Wu, D. R. Turner, P. Y. Wang, X. X. Zhou, "Modeling of TCSC Dynamics for Control and Analysis of Power System Stability", *Electrical Power and Energy Systems*, Vol. 22, 2000, pp. 43 - 49.
- [18]. H. G. Han, J. K. Park, B. H. Lee, "Analysis of Thyristor Controlled Series Compensator Dynamics Using the State Variable Approach of a periodic System Model", *IEEE Transactions on Power Delivery*, Vol.12, No. 4, Oct. 1997, pp. 1744 - 1750.

K.Bhanu Kiran “Power Flow Control between Two Transmission lines by Capacitive Reactance”
International Journal Of Engineering Research And Development , vol. 14, no. 01, 2018, pp. 53–61.