

Noise in Power Line Communication Channel: an Overview

Avinash Shrotriya¹, D.K Saxena², Mohit Kumar Singh³

¹Dehradun Institute of Technology, Dehradun, India

²Department of Electronics and Communication Engineering Dehradun institute of technology, Dehradun, India

³Drona's College of Management and Technical Education, Dehradun

Abstract:- The power line communication technology is now considered as a good alternative for the implementing communication network. Digital networks can be established using the same set of wires that is use to distribute the power signal through the power-line channel(PLC) because powerline networks are excellent infrastructure for broadband data transmission however various noise exist due to stochastic change in the network load impedence. This paper is an attempt to identify different type of noise in PLC channel and investigate the performance of indoor channel of PLC system. The noise seen in the power-line channel varies with frequency, time and from line to line .in this paper we classify different type of noises its characteristics and the process to remove it from power line channel.

Keyword:- Plc, Ofdm.Middleton A, Nakagami-M Distribution..S

I. INTRODUCTION

Powerline communication (PLC) is a term used to identify technologies, equipment, application and services that allow user to communicate over existing powerline[1]. The most attractive advantage of this technology is that the powerline network is the most pervasive and accessible network that reach every power socket in every home. Since the powerline network is already installed there is no need to lay new cables. Effort to this technology began in 1830[2], when narrowband application were developed but it was only in 1990s idea of using residential power grid to offer value added digital communication services become more popular due to the development of homeplug powerline alliances; it has established specification heading for data rate as high as 200 MBPS[3].

Although PLC technology has advantage of requiring no new wire. The major obstacle is its wide-spread used in broadband communication which results electromagnetic interference (EMI) and noise.Noise in PLC channel is classified into three main categories that are colored background noise, narrowband noise and impulsive noise. Colored background noise results from the simulation of different noise source of low power present in the network and usually characterized with a PSD decreasing with frequency [1]. Narrow band noise seems from the existing from radio broadcasting from long, middle and sort wave ranges. Impulsive noises generatedsignificant among the noise type present in PLC networks.

Although some noise model proposal can be found in literature, there practical value generally varies limited, because most of them describe bottom up approach describing the behavior of network. Only the work reported in [4] present noise model which is based on measurements. However like the other models mentioned above it restricted to frequency range below 150 Khz.

In next section review the power line channel model .A detailed characteristics of different type of noises found in power lines is describe in section 3 and in section 4 we describe the channel coding technique for indoor powerline communication channel.

II. POWERLINE CHANNEL MODEL

The power line channel model can be considered as a series of discrete stationary state that need to be understand for successful PLC. In general power line can be modeled as time varying frequency selective fading channel withnumerous noise source. More simply the power line transfer function can be given as [3]

$$H(f) = \sum_l^{L-1} g_l e^{-(\alpha_0 + \alpha_1 f) d_l} e^{-\frac{j2\pi f d_l}{v}} \dots\dots\dots (1)$$

Where L is the total number of reflecting path, g_l is the complex tap factor for each path, α₀ and α₁ are attenuation factor, d_l is the path length v is the velocity of the propagation.

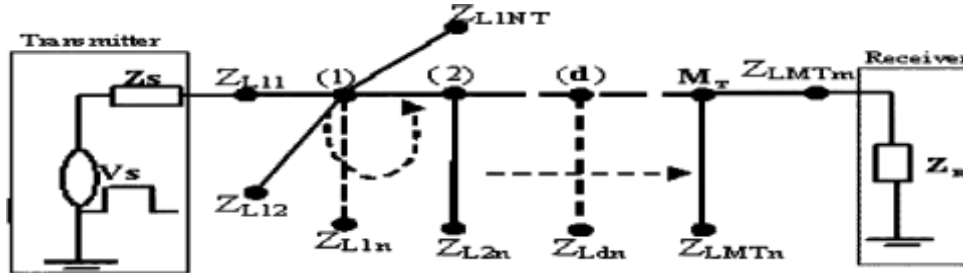

Fig: 1 - power line network with distributed branches

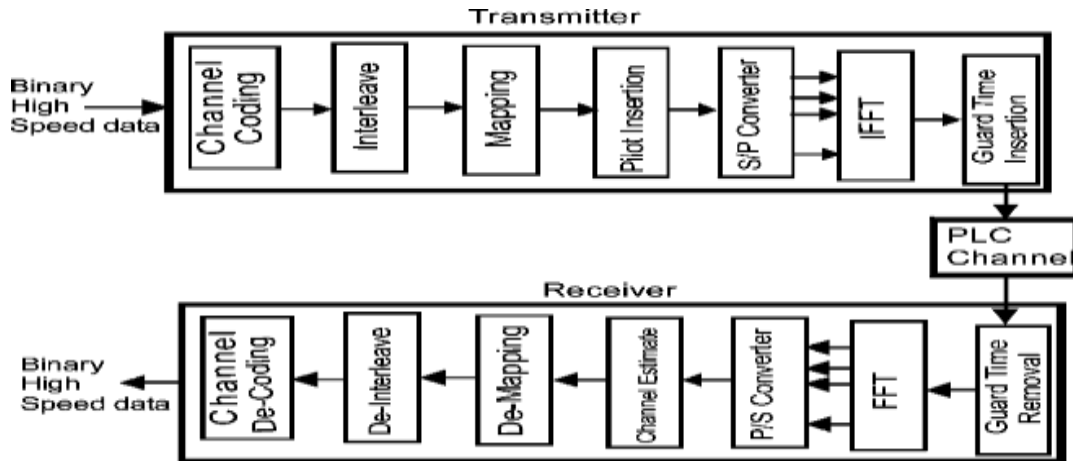

Fig: 2 - power line channel block diagram of transmitter and receiver

III. NOISE MODEL

In time domain, the received signal of power line channel is represented by a standard linear convolution operation that is in discrete form it is given as [1, 2]

$$r(k) = \sum_{n=0}^{N-1} h(l, k)s(k - dn) + \eta_{\text{background}}(k) + \eta_{\text{arrowband}}(k) + \eta_{\text{impulse}}(k) \dots\dots\dots(2)$$

Where $r(k)$ represent the received signal, $s(k)$ represent spread spectrum signal to be transmitted, d_n and N represent individual delay for multipath and number of significant multipath component respectively. Only the work reported by O.hoojen[4] present the noise model which is based on measurement are:

a) **Colored noise:** it is no stationary noise.it is also known as fluctuation noise because can rise to considerable levels when certain appliances are switched on. The model of the model of the colored noise is similar

To the Additive White Gaussian noise (AWGN)

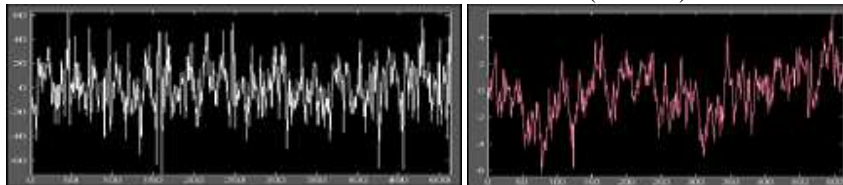

Fig:3- Voltage of noise $n(t)$ a) white noise b) coloured noise

b) **Background Noise:** - background noise is caused by assembling of multiple sources of noise with low power. It represent high level noise that exponential decay to spectrally flat Gaussian white noise at approximate 3mhz. in a high frequency limit it can be assumed as spectrally flat despite of its low amplitude relevant in PLC due to significant signal attenuation experience in channel [1,7]. It can be described by a PSD [7, 10]

$$s_n(f; N_0, N_1, f_1) = N_0 + N_1 \exp(-f/f_0) \dots\dots\dots(3).$$

Where N_0 is the constant noise power density, N_1 and f is the parameter of exponential function.

To model the background noise characteristics in PLC channel long term measurement were carry out from 1-30Mhz.the probability distribution of time domain noise amplitude resemble Nakagami-m distribution function[7]

$$F_n(r)= \frac{2}{\Gamma(m)}(m/\Omega)^m r^{2m-1} \exp(-mr^2/\Omega); \quad r>0 \quad (4)$$

Where r is the random variable , p is the probability of corresponding random variable $\Gamma(m)$ is the gamma function, Ω is the mean power of random variable and m is the shaping parameter of the nakagami- m distributed random variable $n=n_I + jn_Q$. While $\Omega=E \{r^2\}$ denote the power of the same. The argument $\theta=\tan^{-1}(n_Q/n_I)$ is also random and distributed randomly over a complex phase plane $\theta \in (-\Pi, \Pi)$.

It is well known that if $m=1$ Nakagami-m PDF reduce to Rayleigh PDF

$$F_n(r) = 2r/\Omega \exp(-r^2/\Omega); \quad r>0 \quad (5)$$

b) Narrowband noise: - it is source by external RF pickup of numerous radio systems. In the discrete sampling space narrowband noise can be modeled as the output of the band pass filter driven by white Gaussian noise. It can be expressed as [8]

$$n_{nb}(k) = \sum_{n=1}^N (W_n(k) \sin(2\Pi f_k + \theta)) \quad (6)$$

Where N is the number of wave at different frequency f , W_k is amplitude and phase θ is randomly established from interval $[0,2\Pi]$. It is found that n_{nb} is 30dB greater power level than 1Mhz. there for this type of noise can be a source of degradation.

c) **Impulsive Noise:** - Non stationary noise is represented as impulsive noise. Impulsive noise is generated from connected electric appliances. It cause bit or burst error in the data transmission. Middleton's class 'A' noise model is one of the appropriate model for impulsive noise environment []. It can be classified into three group according to three group according to their behavior w.r.t main cycle [9]

- 1) *Periodic Synchronous with main*
- 2.) *Periodic asynchronous with main*
- 3.) *Aperiodic*

Periodic synchronous with the main is a cyclostationary noise synchronous with the main and with a frequency of 50Hz/100Hz. It is commonly originated by silicon controlled rectifier (SCR) in power supply. Periodic asynchronous with the main has been traditionally considered to be formed by a periodic impulse with rate between 50Khz and 200Khz,in addition to its high repetition frequency this noise type also exhibits lower periodicity equal to the main and so, it can also be categorized as cyclostationary noise. Aperiodic impulse noise has a sporadic nature mainly due to transient cause by the connection and disconnection of electric devices.This noise may cause bit or burst error in data transmission. Middleton class 'A' noise model is one of the appropriate model for impulsive noise environment [10, 11, 12, 13].

Based on the model the combination of impulsive noise and background noise is a sequence of i.i.d complex random variable with the probability density function(PDF) of class 'A' noise given by [13]

$$P_2(z)=\sum_{m=0}^{\infty} \frac{a^m}{m!} \frac{1}{2\pi\sigma_m^2} \exp(-z^2/2\sigma_m^2) \quad (7.1)$$

$$\alpha_m = e^{-A} \frac{A^m}{m!} \quad (7.2)$$

$$\sigma_m^2 = \sigma_g^2 \{(m/A)+\tau\}/\tau \quad (7.3)$$

$$\sigma_z^2 = E\{z^2\} = \{e^{-A} \sigma_g^2\}/\tau \sum A^m/m! (m/a+\tau) \quad (7.4)$$

where m is the number of impulsive noise sources and is characterized by Poisson distribution with mean parameter A called impulse index(which is the product of the average rate of impulsive noise and mean duration of typical impulsive)[13] . Γ is the Gauss impulse power ratio(GIR) which represent the ratio between

the variance of Gaussian noise component σ_g^2 and the variance of impulsive component σ_m^2 . the variance of noise σ_z^2 is given in [14].

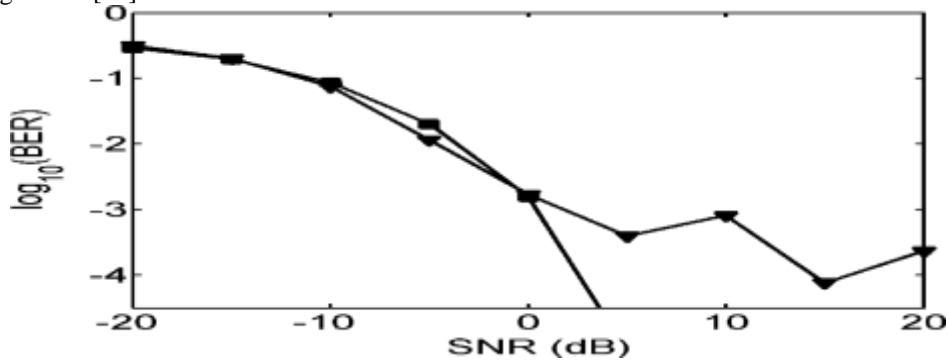

Fig:4. PLC Performance in a noise limited channel

IV. CHANNEL CODING TECHNIQUE

The impulsive noise and frequency selective behavior of power line networks cause burst noise which hampers high speed communication. To overcome burst noise interleaved coding has been adopted. These include interleaved block code and interleaved convolution code. Recently low density parity check (LDPC) codes were proposed [7]. In few paper concatenated Reed Solomon codes (RS) and interleaved vertebri channel coding used due to its effectiveness of burst error correction[16] [17][18].

These concatenated coding scheme consist of an outer block code over GF(2^B) and inner binary convolution code. Assuming Interleaving between vertebri decoder and Reed soloman decoder is sufficiently long to breakup long burst of error out of the decoder , the Reed soloman symbol error Probability (p_B) for symbol in GF(2^B) can be upper bounded by simple union bound as in eqn

$$P_B \leq B p'_b \dots\dots\dots (8)$$

Where parameter p'_b is the probability ever of the output of the viterbi decoder which can be expressed by eqn [19][20].

$$P_b < R_c \sum_{d=d_{free}}^{\infty} B_d P_2(d) \dots\dots\dots (9)$$

The parameter d_{free} and R_c are the free distance of convolution code and code Rate and B is total number of bit error that occur in All of the incorrect path in their end differ from the correct path in exactly “d” position. The total error probability of the RS code Account for decoder failure probability or decoder error probability is given byEqn (10)

$$P_w \leq 1/n^2 \sum_i (n_{2i}) p_B^i (1-p_B)^{n-1} \dots\dots\dots (10)$$

V. CONCLUSION

In this paper, an innovative approach is applied to impulsive noises which are studied directly at their sources. Measuring Noise at the source led us to analyse much less noises compared to noise measurements at the receiver side, and to establish a correction with effective in device noise generators Characterizing noise at source had made it possible to propose an impulsive noise model for each electrical device. And a random generator of impulsive noise at receiver was also proposed. A model for PLC channel based on the time-variant linear-filter channel. The additive noise on the channel was shown to be collection of four noise types these are spectrally flat noise with a power- spectral density that decreases for increasing frequency, colored noise, background noise, narrowband noise and Impulsive noise. This paper also attempt to find a channel coding technique suitable for indoor powerline communication channel.

REFERENCES

[1]. J. Meng,” Noise analysis of power line communication using spread spectrum”, *IEEE Trans. Power. Del.*, Vol.22, No.3, pp1470-1476,July 2007
 [2]. M.Tlich,”Novel approach for PLC impulsive noise modeling”, ISPLC’07,pp505-510,2007
 [3]. M. Zimmermann, K. Dostert, “A Multipath Model for the Power LineChannel”, *IEEE Trans. Commun.*, vol. 50, no. 4, pp.553-559, April 2002.

- [4]. Olaf G. Hooijen, "A Channel Model for the Residential Power Circuit Used as a Digital Communications Medium", *IEEE TRANSACTIONS ON ELECTROMAGNETIC COMPATIBILITY*, VOL. 40, NO. 4, pp. 331-336, NOVEMBER 1998
- [5]. O. Hooijen, "On the Channel Capacity of Residential Power Circuit used as digital communication circuit," *IEEE Commun. Lett.*, Vol.2, No.10 pp. 267-268, 1998.
- [6]. M. Zimmermann and K. Dostert, "Analysis and modeling of impulsive noise in broad-band powerline communications," *IEEE Transactions on Electromagnetic Compatibility*, vol. 44, no. 1, pp. 249-258, February 2002.
- [7]. H. Meng, S. Chen, Y. L. Guan, C. L. Law, P. L. So, E. Gunawan, T. T. Lie, "Modeling of transfer characteristics for the broadband power line communication channel," *IEEE Trans. Power Delivery*, vol. 19, pp.1057-1064, July 2004.
- [8]. V. Degardin, M. Lienard, A. Zeddani, F. Gauthier, and P. Degauque, "Classification and characterization of impulsive noise on indoor power line used for data communications," *IEEE Transactions on Consumer Electronics*, vol. 48, no. 4, pp. 913-918, November 2002.
- [9]. M. Tlich, A. Zeddani, F. Moulin, and F. Gauthier, "Indoor Power line Communications Channel Characterization Up to 100 Mhz-Part II: Time-Frequency Analysis," *IEEE Transactions on Power Delivery*, vol.23, pp. 1402-1409, 2008.
- [10]. Manfred Zimmermann, Klaus Dostert, "A Multi-Path Signal Propagation Model for the Power Line Channel in the High Frequency Range" ISPLC'1999, PP.44-51, U.K. 1999.
- [11]. D. Middleton, "Procedures for determining the parameters of the first order Canonical models of class A and class B electromagnetic interference" *IEEE Trans. Electromagn. Compat.*, vol. EMC-21, no.3, pp. 190-208, Aug. 1979.
- [12]. D. Middleton, "Statistical-physical model of electromagnetic interference," *IEEE Trans. Electromagn. Compat.*, vol. EMC-19, no. 3, pp.106-126, Aug. 1977.
- [13]. J. Anatory, N. Theethayi, and R. Thottappillil, "Channel characterization for indoor power-line networks," *IEEE Trans. Power Del.*, Vol.24, No.3, July 2009
- [14]. P. Amirhashi, S. M. Navidpour, and M. Kavehrad, "Performance analysis of uncoded and coded OFDM broadband transmission over low voltage power-line channels with impulsive noise," *IEEE Trans. Power Del.*, vol. 21, no. 4, pp. 1927-1934, Oct. 2006.
- [15]. C. Hsueh, N. Wang, W. Chan, and P. Jain, "Improving powerline communication standard with LDPC code," *EURASIP J. Advances in Signal Processing* Vol.2007 pp.1-9.
- [16]. K. Y. Lice and J. Lee, "Recent results on the use of concatenated Reed-Solomon/Viterbi channel coding and data compression for space communication," *IEEE Trans. Commun.* vol. COM-32, no.5, pp.518-523, May 1984.
- [17]. R. D. Cideciyan, E. Eleftheriades, and M. Rupp, "Concatenated Reed-Solomon/Convolution coding for data transmission in CDMA based cellular system," *IEEE Trans. Commun.*, vol. 45, no.10, pp. 1291-1303, Oct 1997.
- [18]. Y. F. M. Wang and K. B. Letaief, "Concatenated coding for DS/SS transmission with wireless communication," *IEEE Trans. Commun.* vol. 48, no.12, pp. 1965-1969, Dec 2000
- [19]. J. G. Proakis, "Digital Communication," 4th Edition New York; McGraw-Hill, 2001.
- [20]. A. J. Viterbi, "Convolution code and their performance in communication system," *IEEE Trans. Commun.* vol-com-19, no.5, pt.1 pp. 751-772, Oct 1971.



AVINASH SHROTRIYA is received his B.Tech degree in electronics and communication engineering from ICFAI university Dehradun, India. He is working toward his master degree in digital communication from Dehradun institute of technology, Dehradun (Uttarakhand Technical University, Dehradun). His research is focused on PLC.

2. **Prof. D.K Saxena** is prof. in ECE department in Dehradun institute of technology, Dehradun, India

3. **MOHIT KUMAR SINGH** is pursuing his B.tech Degree in electronics and communication engineering from Drona's college of management and technical education, Dehradun (U.T.U Dehradun, India).