

A Novel Method on Development of A Grid-Connected Wind/Pv/Bess Hybrid Distributed Generation System

S.Radha Krishna Reddy¹, Ch.Kamal², Dr. JBV Subrahmanyam³, Anwarunnisa Begum⁴, Y.Udaykiran⁵

^{1,2,4&5} Electrical & Electronics Engineering Dept Holy Mary institute of Technology & Science, keesara, RR District, Hyderabad, AP, INDIA

³ Electrical & Electronics Engineering Dept., Bharat Institute of Engineering & Technology, mangalpally, ibrahimpatnam, RR district, Hyderabad, AP, INDIA 501 510

Abstract—A grid-connected hybrid distributed generation system, composed of PV(photovoltaic) array, wind turbine and battery, is proposed for various power transfer functions to the distribution network. The proposed system has several operation modes which are normal operation, power dispatching, and power averaging, according to coordinate control of the BESS(Battery Energy Storage System) and grid inverter. PV array and wind turbine are individually controlled to operate at the maximum power point for the most use of renewable energy. The BESS operates as an energy buffer to flexibly shift the generation from the renewable energy sources without excessively frequent shifts between battery charging and discharging. A grid interface inverter regulates the generated power injection into the grid. Developed prototype system design and experimental results are presented to demonstrate the performance and to validate the proposed system during its operation modes.

I. INTRODUCTION

Most renewable energy source such as photovoltaic and wind turbine heavily rely on the ambient environmental conditions therefore produce unpredictable output characteristics. The other renewable energy source such as the micro turbine and fuel cell system don't have ambient dependency but their out response characteristics are so slow that they can't hardly meet the dynamic load conditions [1-2]. Therefore renewable energy sourced generation systems are weak in stable and sustainable power supply. However, some of them, like solar irradiance and wind speed, have complementary profiles [3]. It has been reported that in weak grids, the wind/solar hybrid system is more reliable than single wind or PV generation since it suppresses rapid change in the output power of the single source such as the wind turbine system [4]. Grid interface of the hybrid system with battery storage or fuel cell generation may improve system stability and reliability [5-6].

This paper describes prototype system design and principle of a wind/PV/BESS hybrid system in grid interface operation and its experimental test results by several operation modes which are normal operation, power dispatching and power averaging. The wind and solar systems are regulated to obtain the maximum energy from given wind and solar conditions for efficient operation. The battery storage system is utilized to smooth the output fluctuation of the entire hybrid system. Energy control of the entire system and energy flow between systems and grid are based on power electronic interface. Experimental test results present the dynamic control performance of the proposed hybrid generation system and also demonstrate the feasibility of output averaging with a battery storage system at the hybrid generation system. Figure 1 presents a configuration of the proposed grid-connected hybrid generation system.

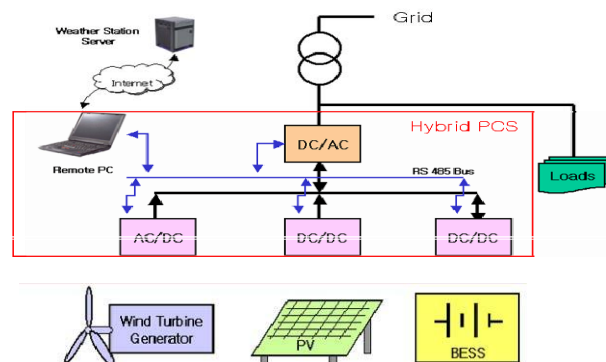

Fig. 1. A configuration of the proposed hybrid generation system

II. PROPOSED HYBRID GENERATION SYSTEM

System Configuration

Figure 2 is a block diagram of the proposed hybrid generation system. This hybrid system includes a wind

turbine and a photovoltaic as energy sources, battery storage as an energy buffer, a common dc link, power electronic converters for conditioning the power associated with the hybrid components, and a grid-connected inverter.

Figure 3 shows a developed prototype of the proposed hybrid generation system. It consists of 10kW BESS, 10kW PV PCS, 20kVA Wind Turbine PCS and 30kVA Grid-Connected Inverter System from upper layer. Each PCS is controlled by its own TMS320C32 based control platform and communicate with hybrid system controller software in PC by RS485 multi-drop serial communication.

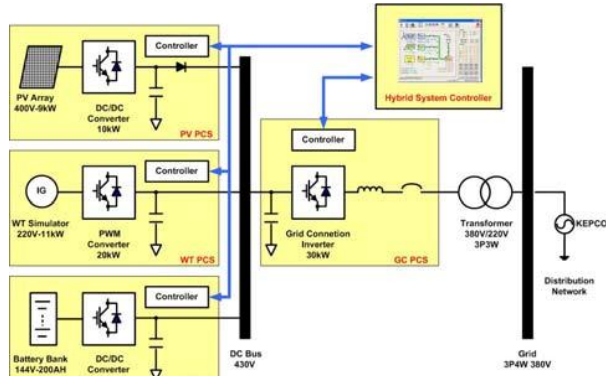

Fig. 2. A block diagram of the proposed hybrid generation system



Fig. 3. A prototype of the proposed hybrid generation system

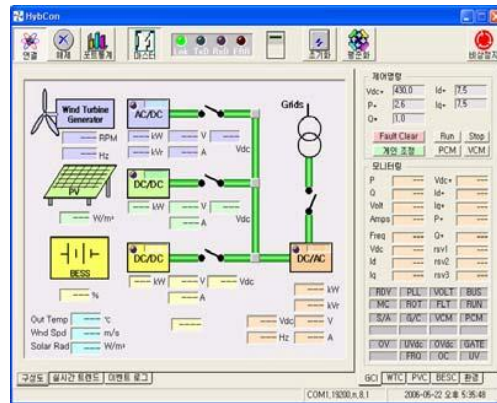

Fig. 4. An interface window of the hybrid system control software

The photovoltaic system consists of a 9kW photovoltaic array and a 10kW boost dc-dc converter that raises the array voltage to a higher common dc voltage level. The PV system operates under maximum power point tracking (MPPT) control to create the maximum energy from solar irradiance variation. The wind system is composed of 11kVA

induction generator based wind turbine simulator and a 20kVA variable voltage variable frequency PWM converter whose operating scheme is to capture the maximum energy from varying wind speed by regulating the wind blade speed. Figure 4 is an interface window of hybrid system controller software. System operation and control parameters setting can be performed by this software interface.

III. SYSTEM SPECIFICATIONS

Followings are specifications of the prototype hybrid generation system components.

PV Array (Total 3 PV arrays were used)

- Module Name : GMG 10530
- Maximum Open Voltage : 434V
- Maximum Output Power : 3184W

PV PCS

- Converter Type : Boost DC-DC Converter
- Switching Device and Frequency : IGBT, 10kHz
- Power Rating : 10kW
- Input PV Voltage Range : 200V ~ 400V (DC)
- Output Voltage Range : 350V ~ 600V (DC)
- Control : MPPT (Incremental Conductance Method)

Battery Bank

- Nominal Voltage : 144V(12 series connection)
- Rated Capacity : 200AH
- Battery Type : VRLA Type

BESS PCS

- Converter Type : Step Up/Down DC-DC Converter
- Switching Device and Frequency : IGBT, 10kHz
- Power Rating : 10kW
- Battery Side Voltage Range : 130V ~ 200V (DC)
- DC Link Side Voltage Range : 350V ~ 600V (DC)
- Charging Control : Bulk/Absorption/Float

Wind Turbine Simulator

- System : RTDS and MG set(Induction Machine)
- Turbine Model : RTDS user define model used
- Generator : MG Set (11kVA 220V)

Wind Turbine Model

- Type : No Pitch Control, Stall Control
- System Rating : 10kVA
- Blade Radius : 3.9m
- Air Density : 0.55 kg/m³
- Rated Speed : 74 r.p.m.
- Rated Wind Speed : 12 m/sec

WT PCS

- Converter Type : 3 Phase SVPWM Converter
- Switching Device and Frequency : IGBT, 10kHz
- Power Rating : 20kVA
- Input Voltage Range : ~ 250V (AC)
- Input Frequency Range : ~ 120Hz
- Output Voltage Range : ~ 600V (DC)
- Control : MPPT, VVVF, Scalar

Grid Inverter

- Converter Type : 3 Phase SVPWM Inverter
- Switching Device and Frequency : IGBT, 10kHz
- Power Rating : 30kW
- Rated Output Voltage : 220V (AC)
- Input Voltage Range : 350V ~ 600V (DC)
- Control : DQ based Current Control

IV. SYSTEM CONTROL

The proposed hybrid system has various operation modes such as normal operation, dispatching operation and power smoothing. Table 1 summarizes power control schemes for the various modes.

Table 1. Power control schemes for operation modes

	Wind	PV	BESS	Grid Inverter
Normal	Variable Speed Control	Maximum Power Point Tracking	Common DC Voltage Control Within a range	Constant DC Link Voltage
Dispatching				Dispatched Power
Averaging				Averaged Power

Normal operation

The hybrid system penetrates as much power into the grid as the PV array and wind turbine generate by dc link voltage control.

Power dispatching

The hybrid system generates the power dispatched by a utility operator or commanded by a user for purpose of utility demand management such as peak load shaving and active load control.

Power averaging

The hybrid system mitigates fluctuating power generated from the PV array and wind turbine, and injects more stable (less fluctuating) power output into the grid.

The wind turbine and PV array operate under variable speed control and MPPT control, respectively, to produce the maximum energy from varying weather conditions such as wind speed and solar irradiance. BESS charges a certain portion of generation from the wind and solar sources or discharges energy stored in the battery. The grid interface inverter regulates the common dc link voltage at a constant value in normal operation, and generates the power ordered by a user or dispatched by a utility operator in dispatching mode. In power averaging mode, the power command of the inverter is set as the value averaged by measuring the sum of power generated in the wind turbine and PV array and filtering the measured value with a low pass filter.

EXPERIMENTAL RESULTS

The hybrid system under different operation modes was tested to validate the performance of the proposed system. The total harmonic distortions (THD) of the current and the power variation at the grid connection point are provided for comparison. The experimental cases are classified in Table 1 and summarised experimental results are listed in Table 2.

Table 2. Experiment results

	Power Variation	THD Variation	Discharging Power
Normal	6.7kW	5.7%	0.0Wh
Dispatching	0.6kW	1.3%	1.7Wh
Averaging	4.2kW	2.1%	0.7Wh

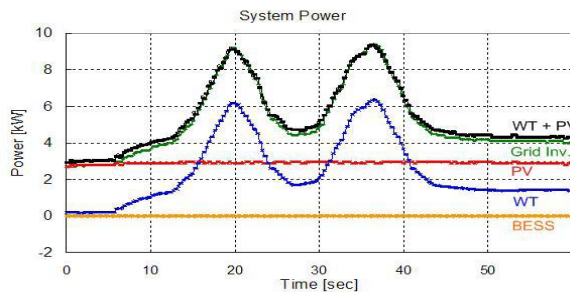

Fig. 5. Experimental results for normal operation mode

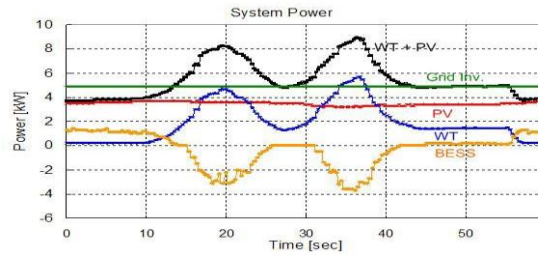

Fig. 6. Experimental results for power dispatching mode

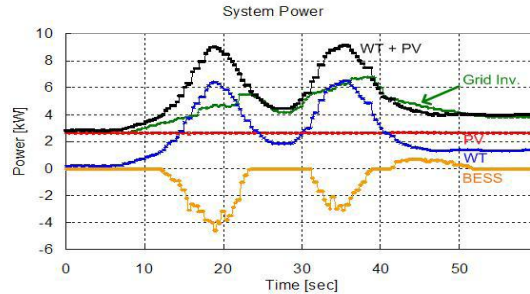

Fig. 7. Experimental results for power averaging mode

Figure 5 presents the experimental result of normal operation mode. The common dc voltage was maintained at 430V and the grid inverter passed all the power from the wind turbine and solar array into the distribution grid. Difference between the summed power of the wind and PV system and the grid inverter power was power loss of the hybrid PCS. THD of inverter current was reversely proportional to the power injection, since the harmonic component ratio to the fundamental component (60Hz) decreased with the greater output current.

Figure 6 presents the experimental result of power dispatching operation mode where the hybrid system was dispatched to generate 5kW for the duration of test. The grid inverter injected constant power irrespective of power fluctuations of the wind and PV systems. When the summed power of the wind and solar sources was greater than the injected power into grid the battery operated in charging mode, and with the wind and solar generation less than the grid injection the battery turned in discharging mode. The dc link voltage was maintained at the upper limit in battery charging mode, and at the lower limit in discharging mode. This BESS operation scheme did not require frequent shifts of the battery operation mode that might give adverse effects on the battery lifecycle. When constant power was injected, THD of output current was constant and there were no voltage fluctuations.

Figure 7 shows the result of power averaging operation mode where the ordered power of the grid inverter was set as low-pass filtering value of the sum of the wind and solar power. Smoothing effect in power injection into grid was clearly seen. Also, fluctuations in THD of the current and the voltage of the PCC became smoother. The battery operation strategy was the same as that of power dispatch operation mode and the dc link voltage was controlled between the pre-set limits, which did not require too many battery mode changes.

V. CONCLUSIONS

A multifunctional grid-connected wind/PV/BESS hybrid generation system has been proposed. The principle of the proposed system and power control scheme for multi-operation modes were described. System performance was verified by experimental tests. A 30kW prototype was implemented and tested. Experimental results demonstrated that the proposed system was capable of supplying flexible and stable power into grid with coordination control of BESS and a grid interface inverter, and simultaneously maximizing use of the individual renewable energy sources. The proposed system has environmentally-friendly energy sources, and user- or utility-friendly operation strategy that power injection into network is dispatch able or less fluctuating. System economy, however, is another since renewable energy systems have inherently low cost-effectiveness. For optimal operation system engineering including sizing of components, particularly BESS, should be considered.

REFERENCES

- [1]. Jinhong JEON, Suelki KIM, Changhee CHO, Jongbo AHN and Eungsang KIM, December 2006, "Development of Simulator System for Microgrids with Renewable Energy Sources", *Journal of Electrical Engineering & Technology*, Vol. 1, No.4, pp 409-413.
- [2]. Seul-Ki KIM, Jin-Hong JEON and Eung-Sang KIM, June 2004, "Modeling of a Variable Speed Wind Turbine in Dynamic Analysis", *KIEE International Trans. Power Engineering*, Vol. 4, No. 2. pp51-57.
- [3]. Fernando Valencaga, Pablo F. Puleston and Pedro E. Battaioito, December 2003, "Power Control of a Solar/Wind Generation System Without Wind Measurement: A Passivity/Sliding Mode Approach", *IEEE Trans. Energy Conversion*, Vol. 18, No. 4, pp. 501-507.
- [4]. Kurozumi, Kazuhiro *et al.*, 1988, "Hybrid system composed of a wind power and a photovoltaic system at NTT Kume-jima radio relay station", INTELEC, International Telecommunications Energy Conference, pp. 785-789.
- [5]. Riad Chedid and Saifur Rahman, March 1997, "Unit Sizing and Control of Hybrid Wind-Solar Power Systems", *IEEE Trans. Energy Conversion*, Vol. 12, No. 1, pp. 79-85.
- [6]. Francois Giraud and Ziyad M. Salameh, March 2001, "Steady- State Performance of a Grid-Connected Rooftop Hybrid Wind- Photovoltaic Power System with Battery Storage", *IEEE Trans. Energy Conversion*, Vol. 16, No. 1, pp. 1-7.