

FPGA Implementation of Scan-to-Scan Discriminator for the Detection of Marine Targets

¹Anala M, ²Fathima Jabeen, ³Vikram Thakur

¹Assistant Professor, Department of ECE, KSSEM, Bangalore, India.

²Professor and HOD, Department of ECE, KSSEM, Bangalore, India.

³Scientist, LRDE, DRDO, Bangalore, India.

Abstract:- For an operational radar, backscatter of the transmitted signal by the elements of the sea surface often places severe limits on the detect ability of returns from ships, missiles, navigation buoys, and other targets sharing the radar resolution cell with the sea surface. These interfering signals are commonly referred to as sea clutter, or sea echo. Maritime surveillance radar experiences serious limitations imposed on their performance by unwanted sea clutter.

In the marine environment, sea clutter might occur at a random position in one scan but not in the next or subsequent scans. In contrast, targets will appear from scan to scan with essentially the same amplitude. The scan-to-scan discriminator eliminates “spiky” clutter by using one of the 3 approaches. They are:

1. Fixed Threshold.
2. Cell Averaging Constant False Alarm Rate (CA- CFAR).
3. Clutter Map.

The output of the scan-to-scan discriminator is then used to tag the speed of small marine targets and gating approach is used to tag the speed of large marine targets.

A Field Programmable Gate Array (FPGA) based hardware architecture for the scan-to-scan discriminator using Fixed Threshold and Clutter Map for radar target detections is developed. Compilation reports and board programming files have been obtained using Quartus II 13.1. Altera-Stratix V FPGA signal processing board has been used as a target device for the implementation purpose.

Keywords:- Radar, scan-to-scan discriminator, sea clutter, fixed threshold, clutter map, CA-CFAR.

I. INTRODUCTION

Radar detection performance is often deteriorated due to the presence of sea clutter. Clutter is the term used to denote unwanted echoes from the natural environment [14]. It implies that these unwanted echoes “clutter” the radar and make difficult the detection of wanted targets. Clutter includes echoes from land, sea, weather (particularly rain), birds and insects. Large clutter echoes can mask echoes from desired targets and limit radar capability [1]. In addition to any possible clutter there will also be always noise. The total signal competing with the target return is the clutter plus noise. In practice there is often either no clutter or clutter dominates or the noise can be ignored. In the first case the radar is said to be Noise limited, in the second it is Clutter Limited.

Sea clutter limits the performance of radar. For sea clutter, the k-distribution is said to be made of two components. There is a fast varying component, with a correlation time of the order of 5 to 10ms. The fast component can be decorrelated pulse to pulse. It is sometimes called the “speckle component” and its statistics can be represented by Rayleigh distribution [7]. The other component has a longer decorrelation time, of the order of seconds. The slowly varying component can be represented by a gamma distribution.

II. METHODS OF THRESHOLD DETECTION

Detection of radar signal is based on establishing a threshold at the output of the receiver. If the receiver output is large enough to exceed the threshold, a target is said to be present. If the receiver output is not of sufficient amplitude to cross the threshold, only unwanted signal is said to be present. This is called threshold detection. Three approaches can be adopted in order to determine the threshold levels. They are:

1. Fixed Threshold.
2. CA-CFAR.
3. Clutter Map.

A. Fixed Threshold

In this case, the signal is compared with a fixed threshold and targets are detected whenever the signal exceeds this threshold. If the threshold level is set properly, the receiver output should not normally exceed the threshold if noise plus clutter alone were present, but the output would exceed the threshold if a strong target echo signal were present.

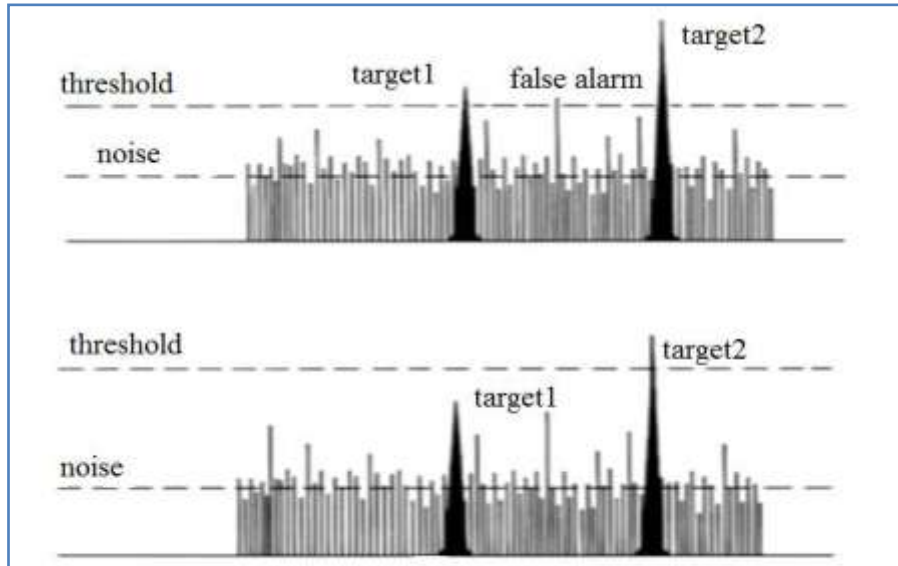

Fig.1 Detection of target using fixed threshold.

If the threshold level were set too low, the unwanted signal might exceed it and be mistaken for a target [14]. This is called false alarm. If the threshold were set too high, unwanted signal might not be large enough to cause false alarms, but weak target echoes might not exceed the threshold and would not be detected. When this occurs, it is called a missed detection.

B. CA-CFAR

The CFAR processor provides considerable better performance than the fixed processor when it comes to following the varying mean level of the clutter. However, in some cases, such as the very spiky or weak clutter, it may be impossible to follow the clutter mean variations. Under these conditions, Ideal fixed processor is more optimal.

A false alarm is “an erroneous radar target detection decision caused by noise or other interfering signals exceeding the detection threshold”. In general, it is an indication of the presence of a radar target when there is no valid target [3]. The False Alarm Rate (FAR) is calculated using the following formula:

FAR =false targets per PRT/Number of range cells

False alarms are generated when thermal noise exceeds a pre-set threshold level, by the presence of spurious signals, or by equipment malfunction. If the detection threshold is set too high, there will be very few false alarms, but the signal-to-noise ratio required will inhibit detection of valid targets. If the threshold is set too low, the large number of false alarms will mask detection of valid targets.

1. Threshold is set too high: Probability of Detection = 20%
2. Threshold is set optimal: Probability of Detection = 80%

But one false alarm arises!

$$\text{False alarm rate} = 1 / 666 = 1,5 \cdot 10^{-3}$$

3. Threshold is set too low: a large number of false alarms arise!
4. Threshold is set variable: constant false-alarm rate.

The false alarm rate depends on the level of all interferences, like noise, clutter or jamming. Near the radar site the influence of the fixed clutter is higher than the noise level. At large distances the influence of the noise level is higher. To achieve a higher probability of detection in large distances by using a lower threshold level, the false alarm rate rises at close range.

Constant false alarm rate (CFAR) detection refers to a common form of adaptive algorithm used in radar systems to detect target returns against a background of noise, clutter and interference [2]. In the radar receiver, the returning echoes are typically received by the antenna, amplified, down-converted and then passed

through detector circuitry that extracts the envelope of the signal. This signal is proportional to the power of the received echo and comprises the wanted echo signal and the unwanted power from external clutter and interference and internal receiver noise. The role of the constant false alarm rate circuitry is to determine the power threshold above which any return can be considered to probably originate from a target. If this threshold is too low, then more targets will be detected at the expense of increased numbers of false alarms and vice-versa, but the number of false alarms will also be low[14]. In most radar detectors, the threshold is set in order to achieve a required probability of false alarm.

If the background against which targets are to be detected is constant with time and space, then a fixed threshold level can be chosen that provides a specified probability of false alarm, governed by the probability density function of the noise, which is usually assumed to be Gaussian [2]. The probability of detection is then a function of the signal-to-noise ratio of the target return.. In this case, a changing threshold can be used, where the threshold level is raised and lowered to maintain a constant probability of false alarm. This is known as constant false alarm rate (CFAR) detection.

In most simple CFAR detection schemes, the threshold level is calculated by estimating the level of the noise floor around the cell under test (CUT). This can be found by taking a block of cells around the CUT and calculating the average power level. To avoid corrupting this estimate with power from the CUT itself, cells immediately adjacent to the CUT are normally ignored (and referred to as "guard cells"). A target is declared present in the CUT if it is both greater than all its adjacent cells and greater than the local average power level. The estimate of the local power level may sometimes be increased slightly to allow for the limited sample size. This simple approach is called a cell-averaging CFAR (CA-CFAR).

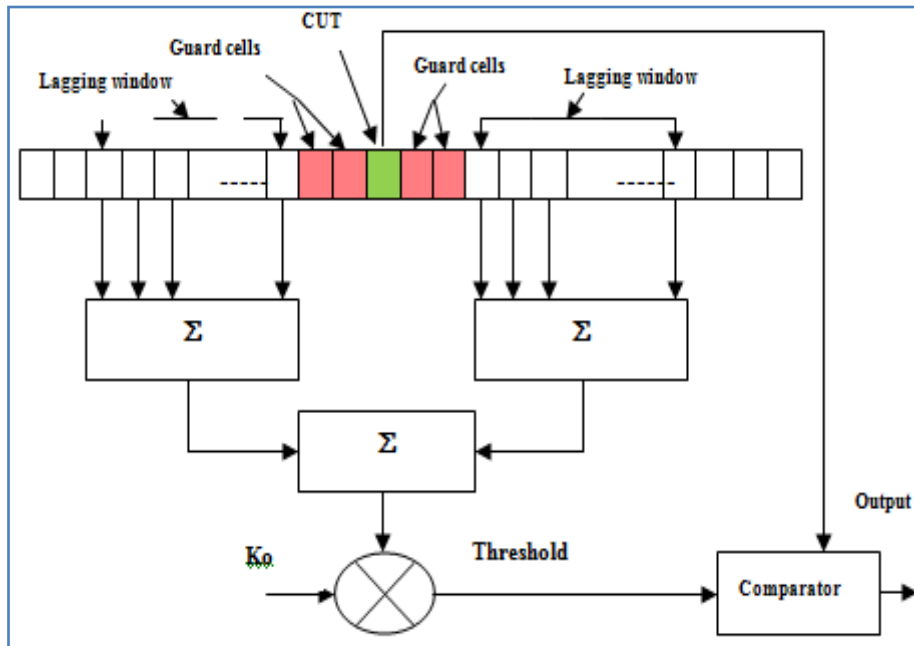

Fig.2 Cell Averaging CFAR (CA-CFAR).

C. Clutter Map

Clutter map stores the magnitude of clutter echoes in a digital memory. The clutter echo stored in each cell of the map can be used to establish a threshold. It is therefore, a form of CFAR [5]. The clutter map establishes the thresholds used for detecting the targets. On each scan, one eighth of the present output is added to the seven eighths of the value stored in the clutter map. Since clutter can change with time, the value of the clutter in each cell is updated periodically by averaging over a large number of scans [6]. The larger the number of scans the more accurate will be the estimate of the clutter and the less the effect of a target that moves through the cell. The map is built up in a recursive manner. About 3 to 10 scans are required to establish a steady state values. The values in the clutter map are multiplied by an appropriate constant to establish the threshold which allows the detection of targets.

A clutter map has an advantage over the CA-CFAR in that it is not affected by edge effects. The response of the clutter map will be reduced when a target of slow speed remains within the cell long enough to affect the threshold. This effect can be reduced by making the map cell greater than the radar resolution cell. Increasing the size of the clutter map cell should not be carried too far, however, since it reduces the interclutter visibility.

III. BLOCK DIAGRAM

A functional block diagram that incorporates the scan-to-scan discriminator is shown in the figure.

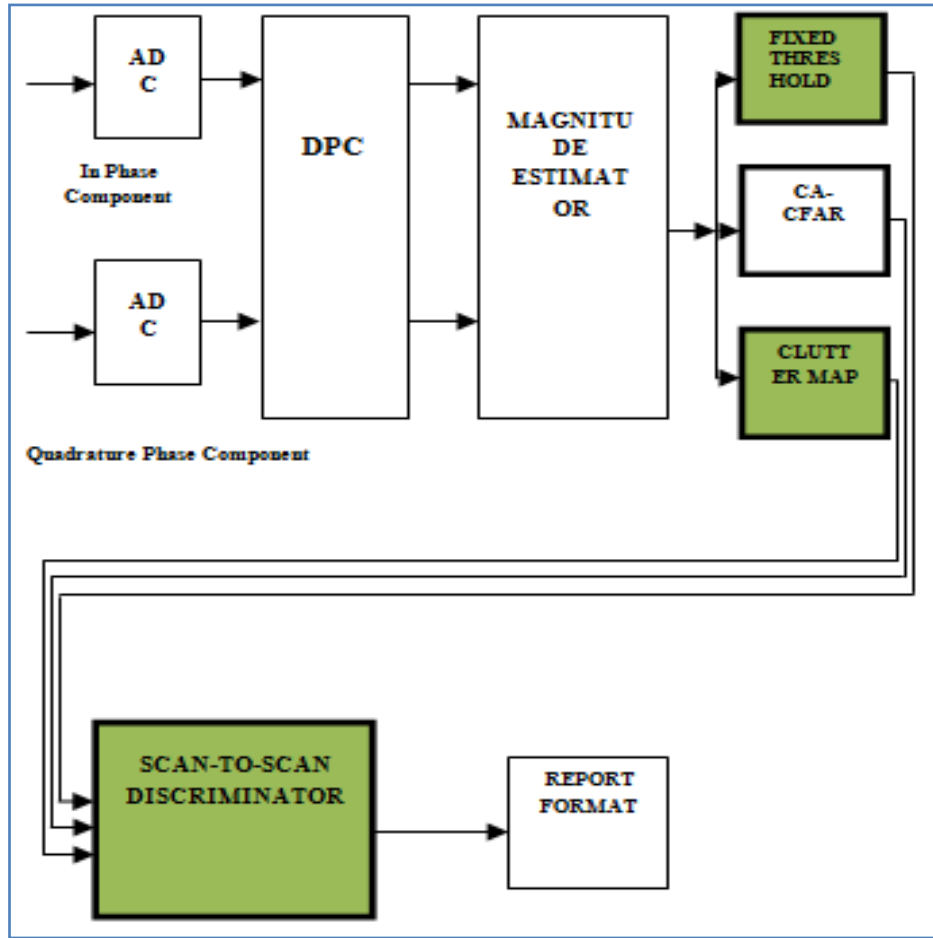

Fig.3 Functional block diagram.

1. Analog-to-digital converter (ADC): The ADC is an electronic integrated circuit which transforms a signal from analog (continuous) to digital (discrete) form. It is not possible to continuously convert the incoming analog signal to a digital output code. Therefore the function of ADC is to quantize the analog signal and then output the corresponding digital code value.

2. Digital Pulse Compression (DPC): A common technique used in Radar Systems to accommodate the seemingly incompatible requirements of transmitting long pulse(in order to allow high mean transmitted power),while achieving fine range resolution is Pulse Compression where the “Range Resolution” is the ability of Radar to clearly distinguish the closely spaced targets. In the simplest form pulse compression amounts to generating the pulse as a frequency -modulated ramp or “chirp” on the transmitter side and on the receiver side, matched filter is used to compress the echo signal.

3. Magnitude Estimator: This performs the amplitude estimation of the complex numbers i.e.it determines the absolute value.

$$Magnitude = \sqrt{\{(I^2) + (Q^2)\}}$$

Where I=in phase component,

Q=out of phase component

4. Fixed Threshold, Clutter Map and CA-CFAR: These are the three approaches used by the scan-to-scan discriminator in order to distinguish between the marine targets and the unwanted signals.

5. Scan-to-Scan Discriminator: In the marine environment, sea clutter might occur at a random position in one scan but not in the next or subsequent scans. In contrast, targets will appear from scan to scan with essentially the same amplitude. The scan-to-scan discriminator eliminates “spiky” clutter by averaging or weighting the amplitudes from several scans. Thus, false alarms are reduced and marine targets can be detected.

6. Report Format: This provides the details about the target detection and strength of the target. This information is displayed on the personal computer (PC).

IV. METHODOLOGY

The scan-to-scan discriminator uses one of the three approaches mentioned below in order to distinguish between the marine targets and the unwanted signals.

A. Scan-to-scan discriminator using fixed threshold.

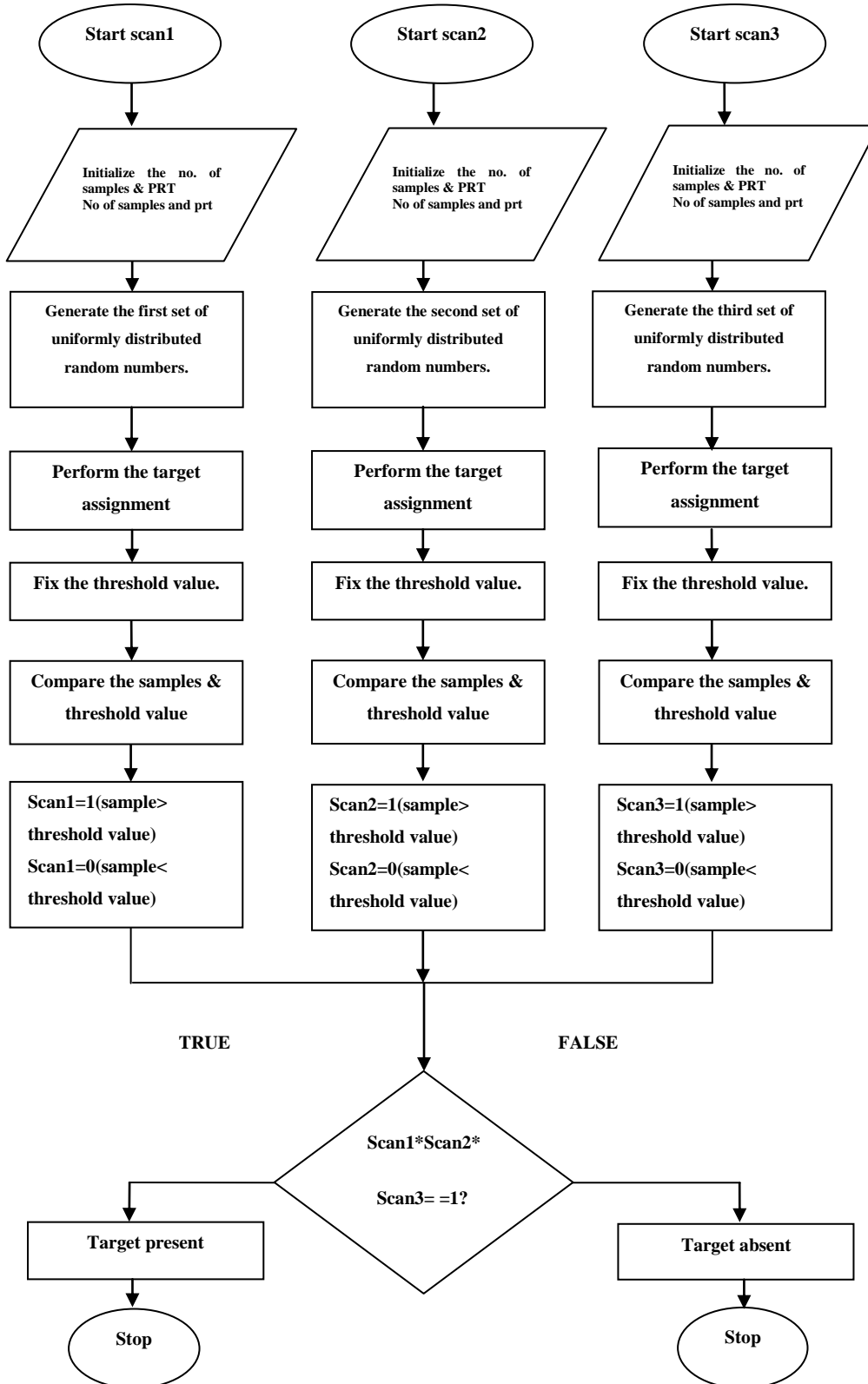

Fig.4 Flow chart for scan-to-scan discriminator using fixed threshold.

B. Scan-to-scan discriminator using CA-CFAR.

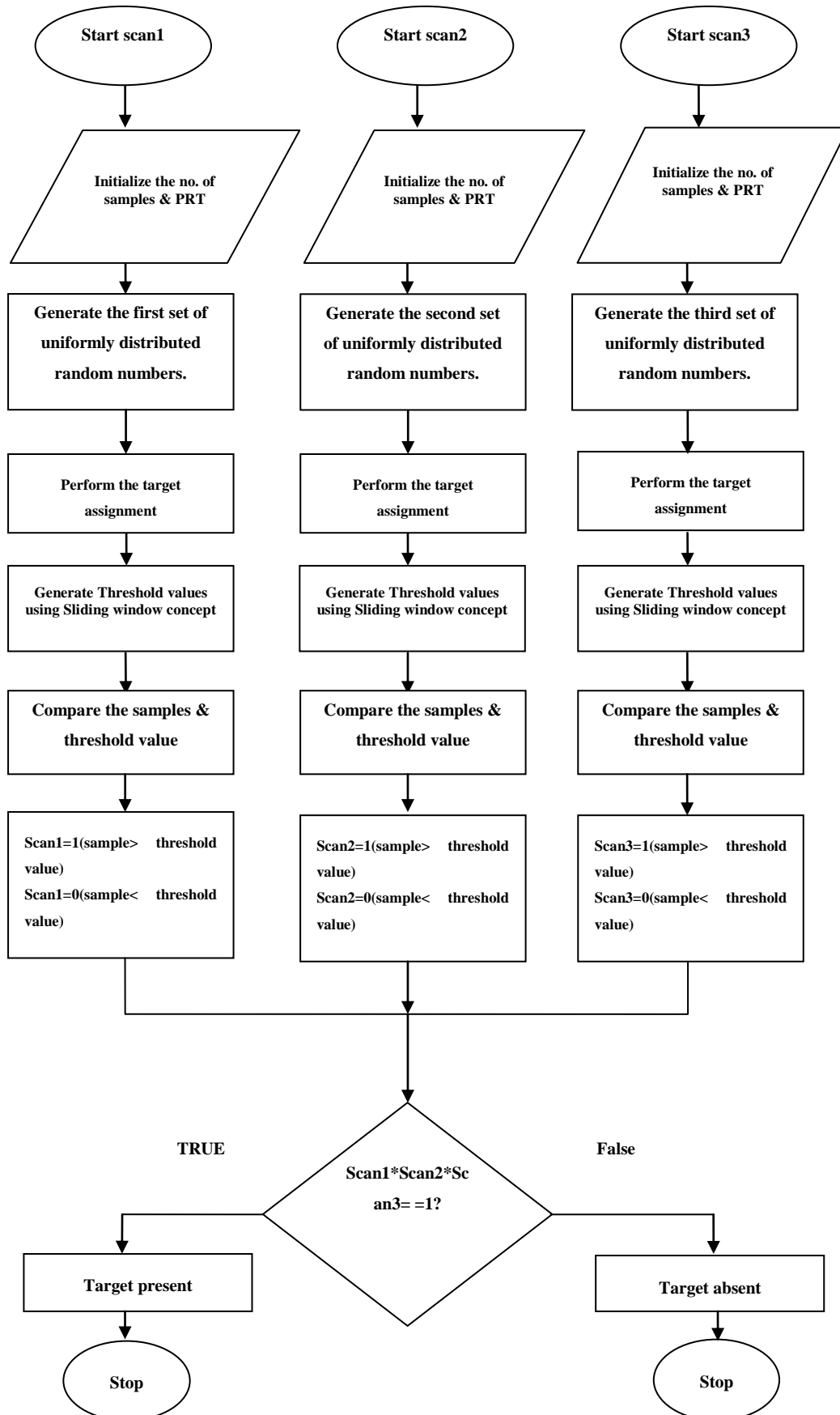

Fig.5 Flow chart for scan-to-scan discriminator using CA-CFAR.

C. Scan-to-scan discriminator using clutter map.

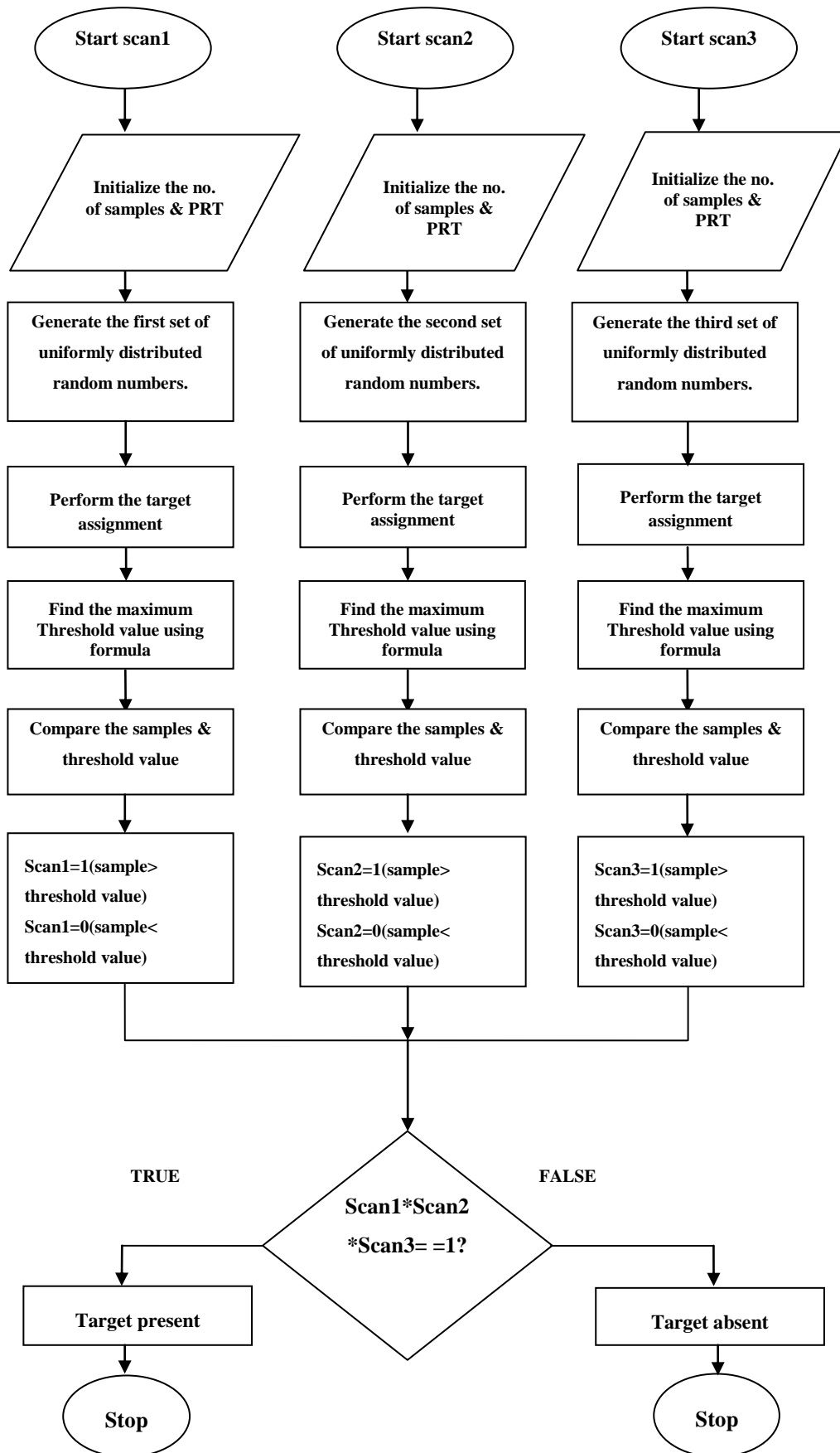

Fig.6 Flow chart for scan-to-scan discriminator using Clutter Map.

V. APPLICATION

A. Tagging the Speed of Small Marine Targets

A target is said to be a small marine target if it occupies a single range cell. The output of each scan is used to tag the speed of small marine targets. The output can be obtained using any one of the three approaches mentioned above.

The target is declared as a —slow moving target if the target occupies the same range cell in all the 3 scans. The target is declared as a —medium speed target if the target occupies the same range cell in either the first and second scan or the second and third scan. The target is declared as a —fast speed target or —false alarm if the target detection is made in either one of the scans or both the first and third scan. The small marine targets tagged using the scan-to-scan discriminator using fixed threshold and clutter map are shown in fig.7 and fig.8 respectively.

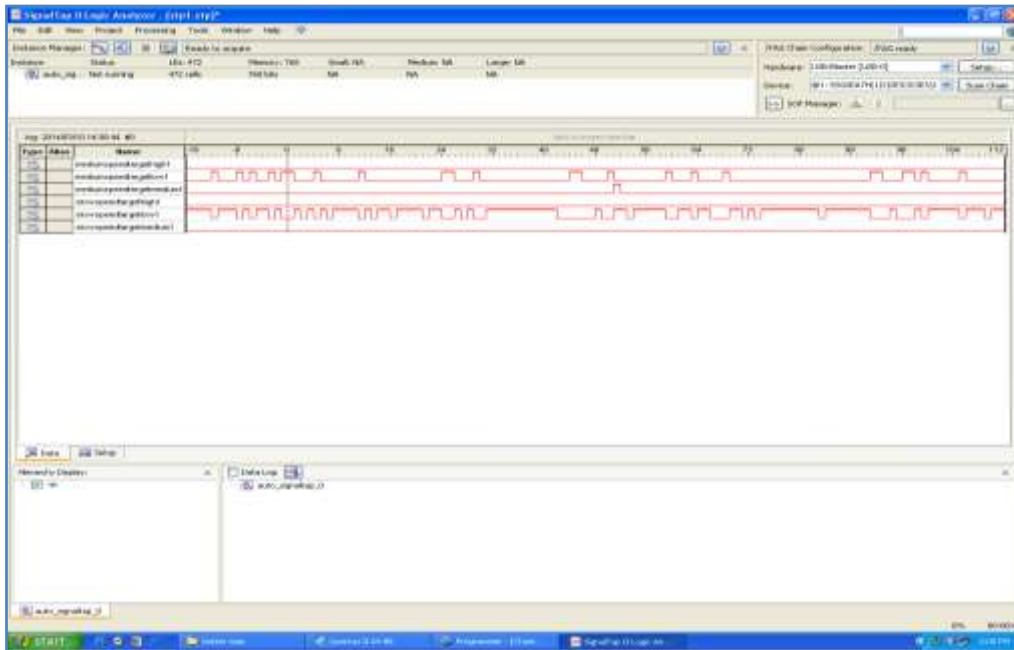

Fig.7 Implementation of tagging the speed of small marine targets using Fixed threshold on Stratix V FPGA.

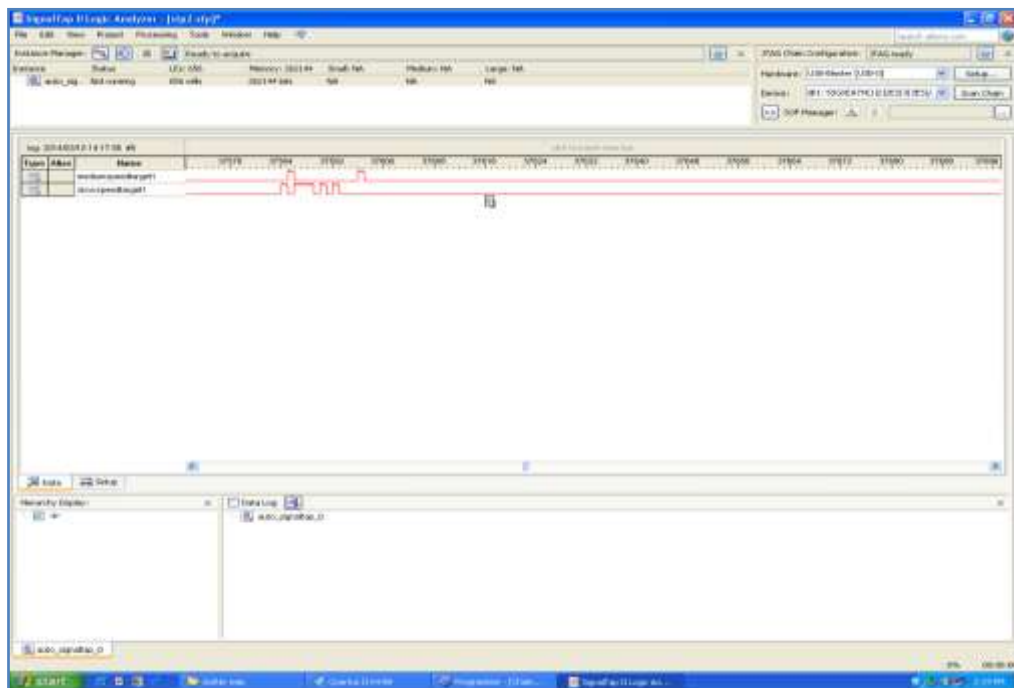

Fig.8 Implementation of tagging the speed of small marine targets using clutter map on Stratix V FPGA.

B. Tagging the Speed of Large Marine Targets using Gating Approach

A target is said to be a large marine target if it occupies two or more range cells. The output of each scan is used to tag the speed of small marine targets. The output can be obtained using anyone of the three approaches mentioned above.

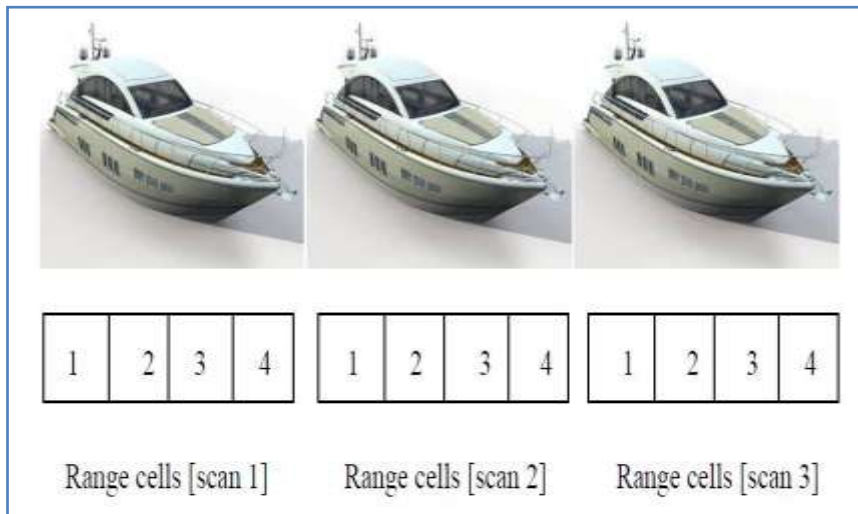

Fig.9 Stationary target since the target remains at the same range cell in all three scans.

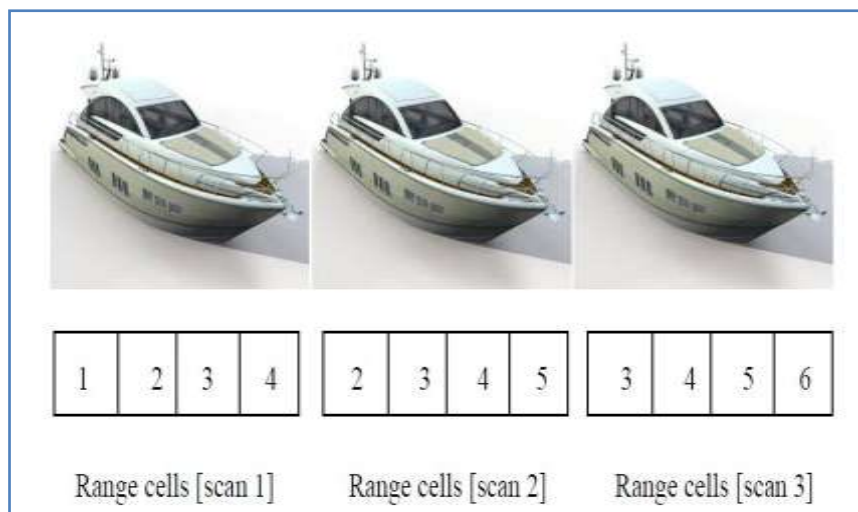

Fig.10 Slow speed target since the target moves from range cell 1 to 3 in three scans.

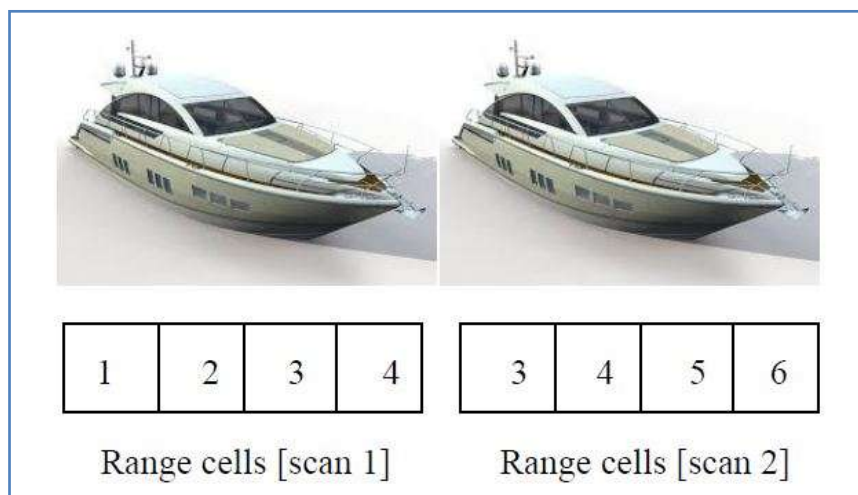

Fig.11 Medium speed target since the target moves from range cell 1 to 3 in two scans.

The target is declared as a —slow speed target if the target moves two range cells in 3 scans. The target is declared as a —medium speed target if the target moves 2 range cells in 2 scans. The target is declared as a —fast speed target or —false alarm if it is neither a slow speed target nor a medium speed target but detection is made in any one of the scans. The large marine targets tagged using the scan-to-scan discriminator using fixed threshold and clutter map are shown in fig.12 and fig.13 respectively.

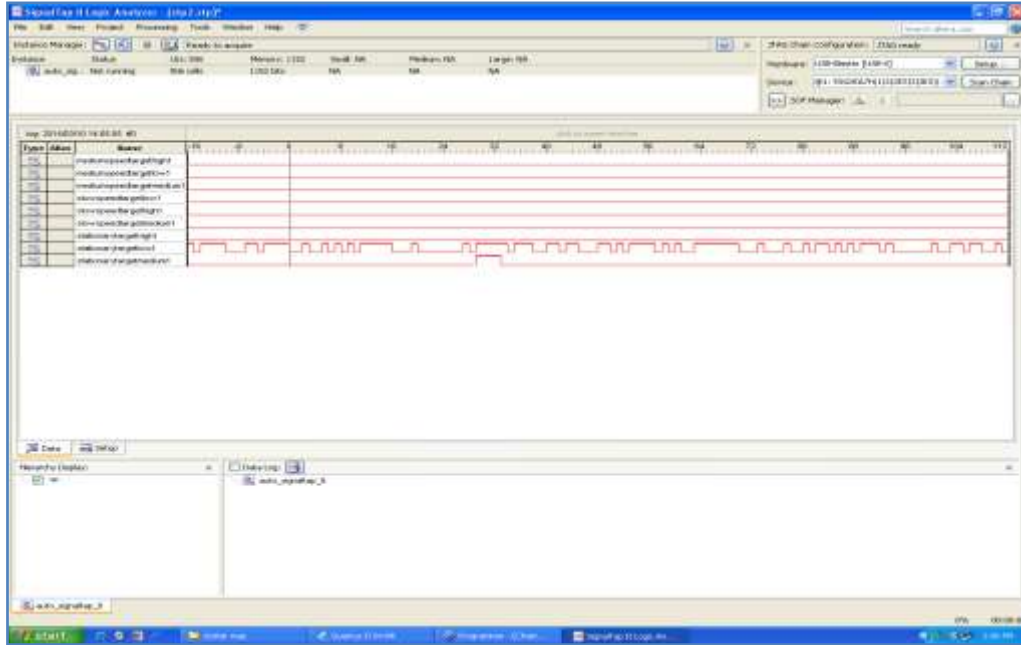

Fig.12 Implementation of tagging the speed of large marine targets using fixed threshold On Stratix V FPGA.

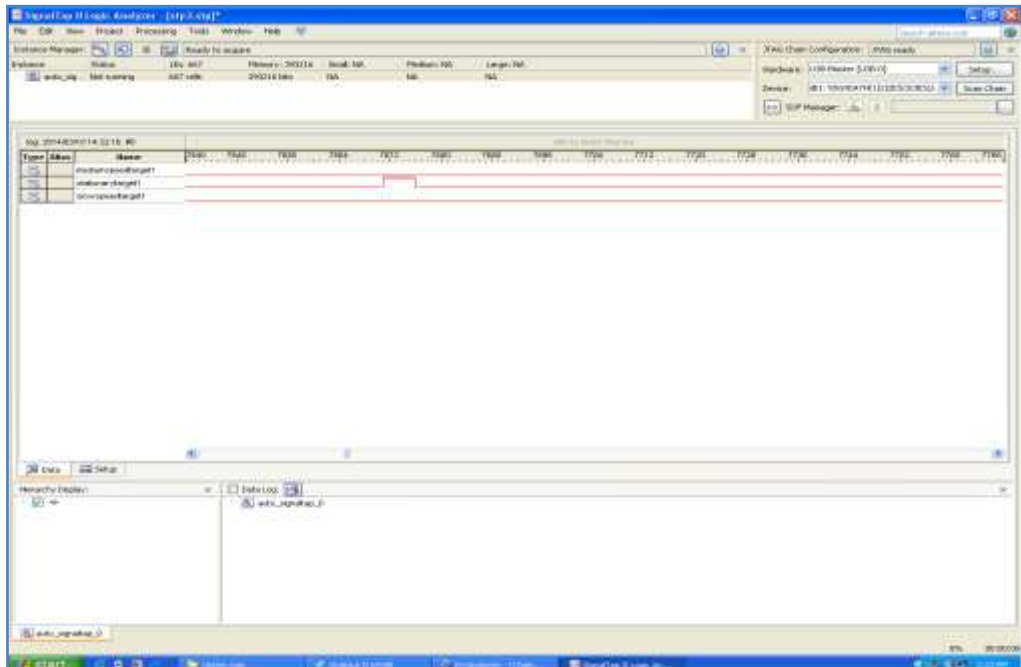

Fig.13 Implementation of tagging the speed of large marine targets using clutter map on Stratix V FPGA.

VI. RESULTS AND DISCUSSIONS

Compilation and synthesis reports are obtained using Quartus II. Once the .sof(s) are obtained, these files are dumped on the FPGA board using the USB blaster. The output of the FPGA can be seen using the Signal Tap II Logic Analyser as shown in fig.14 and fig.15.

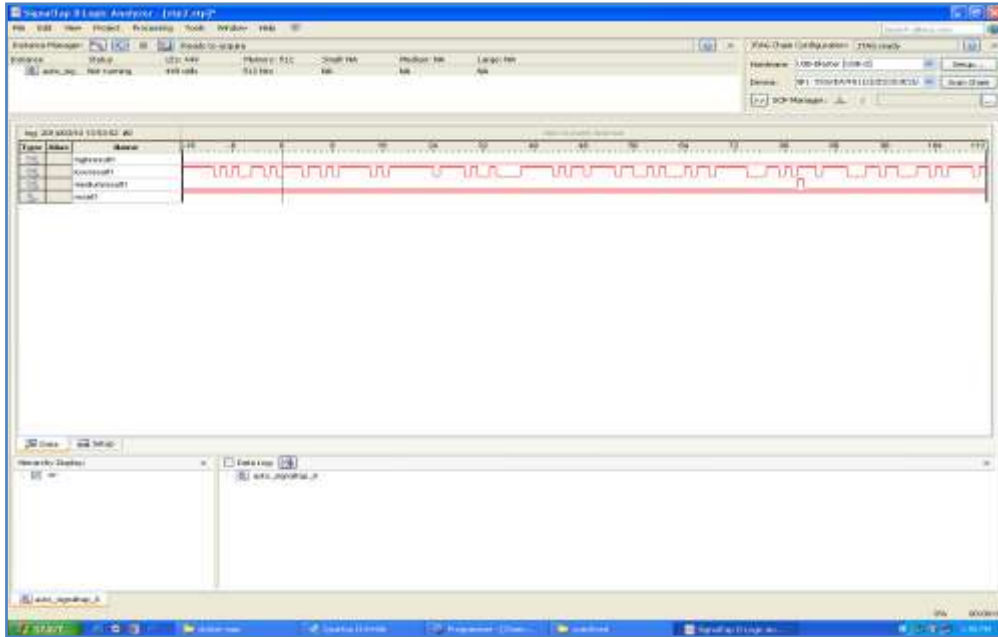

Fig.14 Implementation of scan-to-scan discriminator using fixed threshold on Stratix V FPGA.

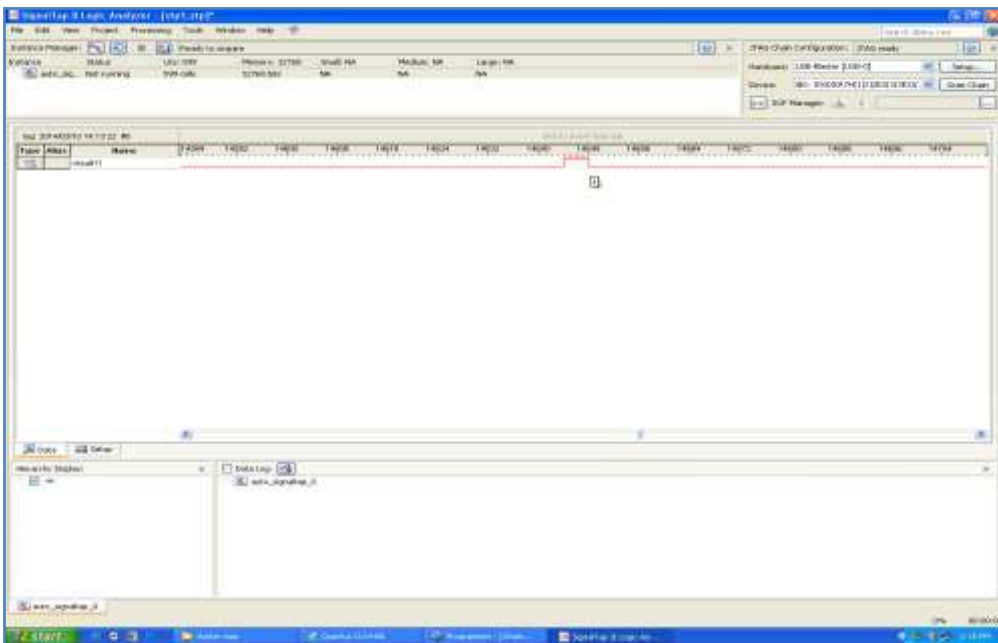

Fig.15 Implementation of scan-to-scan discriminator using clutter map on Stratix V FPGA.

VII. CONCLUSION AND FUTURE SCOPE

This paper has introduced the scan-to-scan discriminator, a simple technique that significantly improves the detection performance. Fine resolution and the ability to detect marine targets makes scan-to-scan discriminator well suited for radar surveillance in waterside security applications. The advantages and drawback of the ideal threshold approach were concisely mentioned. The role of CA-CFAR is to adaptively set a detection threshold so that a constant probability of false alarm is not exceeded and a designed probability of detection is achieved. The intended target echo signal is always immersed in a background which may contain clutter together with an additional superimposed thermal noise. The third approach called the clutter map stores the amplitude of the clutter in the memory. Compilation reports and board programming files have been obtained using Quartus II 13.1. Altera-Stratix V FPGA signal processing board has been used as a target device for the implementation purpose. Experimental results have shown that the proposed scan-to-scan discriminator can remove considerable clutter plus noise while preserving the target. Fine resolution and the ability to detect and tag the speed of marine targets makes the scan-to-scan discriminator well suited for radar surveillance in waterside security applications.

The discussion in this paper has concentrated on the three threshold detection techniques and the scan-to-scan discriminator which in turn uses these three approaches to detect the marine targets. An important aspect of the future radars is likely to be their ability to use the scan-to-scan discriminator in order to tag the speed of marine targets i.e. tag the speed of both small marine targets and large marine targets once the target detection is achieved. The output of the scan-to-scan discriminator can then be used to classify the marine targets as stationary, slow speed, medium speed and fast speed targets. The scan-to-scan discriminator can be enhanced further in order to implement the following features. They are: to design the architecture and implement the CA-CFAR; to distinguish between the fast moving marine targets and false alarms; to determine the range and the angular direction of marine targets.

REFERENCES

- [1]. Ward K D, Baker C J, Watts S, "Maritime surveillance radar, Part I: Radar scattering from the ocean surface", IEE Proceedings on Radar and Signal Processing, Volume 137-Issue: 2, April 1990.
- [2]. Watts S, Baker C J, Ward K D, "Maritime surveillance radar, Part II: Detection performance prediction in sea clutter", Radar and Signal Processing, IEE Proceedings F, Volume 137 -Issue: 2, April 1990.
- [3]. Merrill I. Skolnik, "Introduction to Radar Systems", McGraw-Hill Publications, 3 edition, August 2000.
- [4]. Valentina Ravenni, "Performance Evaluations of Frequency Diversity Radar System", 37th European Microwave Conference, October 2007.
- [5]. Jens Christian Pedersen, "SCANTER 5000 and 6000 Solid State Radar: Utilisation of the SCANTER 5000 and 6000 series next generation solid state, coherent, frequency diversity and time diversity radar with software defined functionality for security applications", Waterside Security Conference (WSS), 2010.
- [6]. Perez F, Asensio A, Gismero J, Alonso J I, Monje J M, Casanova F, Cortijo R, Perez-Ojeda J F, "ARIES: A High Resolution Shipboard Radar", Radar Conference, IEEE, 2002.
- [7]. Musicki D, Suvorova S, Morelande M, Moran B, "Clutter map and target tracking", Information Fusion, 2005 8th International Conference, Volume 1, July 2005.
- [8]. Denny.M, "Simulating sea clutter via the compound-k distribution", Radar System Modelling, IEE Colloquium, October 1998.
- [9]. C. Bouvier, L. Martinet, G. Favier, M. Artaud, "Simulation of radar sea clutter using autoregressive modelling and K-distribution", Radar Conference, 1995.
- [10]. Abdel-Nabi M.A, Seddik K.G, El-Badaway, "Spiky sea and constant false alarm rate processing in high-resolution maritime radar systems", International Conference on Computer and Communication Engineering (ICCCE), 2012.
- [11]. Roberto Perez-Andrade, Rene Cumplido, Claudia Feregrino-Uribe, Fernando Martin Del Campo, "A Versatile Hardware Architecture for a Constant False Alarm Rate Processor Based on a Linear Insertion Sorter".
- [12]. Gandhi P.P., Kassam S.A., "Analysis of CFAR Processors in Nonhomogeneous Background", IEEE Transactions on Aerospace and Electronic Systems, vol. 24, 1988.
- [13]. Lei Zhao, Weixian Liu, Xin Wu, Fu. J. S. "A Novel Approach for CFAR Design", Proceedings of the IEEE, Radar Conference, 2001.
- [14]. Mark A. Richards, James A. Scheer, William A. Holm, "Principles of Modern Radar: Basic Principles", SciTech publishing, 10 edition, 2010.
- [15]. Lehtomaki J.J, Vartiainen J, Juntti M, Saarnisaari H, "CFAR Outlier Detection With Forward Methods", IEEE Transactions on Signal Processing, 2007.
- [16]. N. Moazen, M. R. Akhavan-Sarraf, "A Robust CFAR Algorithm In Non- Homogenous Environments", IET International Conference on Radar Systems, 2007.
- [17]. Meng Xiangwei, Qu Fuyong, "Adaptive clutter map detector in nonhomogeneous environment", IEEE 10th International Conference on Signal Processing (ICSP), 2010.
- [18]. Darko Musicki, Sofia Suvorova, Mark Morelande and Bill Moran, "Clutter Map and Target Tracking", 7th International Conference on Information Fusion (FUSION), 2005.