

## **LPC and Fuel Cell System in Distribution System**

P.Suresh Babu<sup>1</sup>, C.Ganesh<sup>2</sup>, and D.Ganesh Naik<sup>3</sup>

<sup>1</sup>Assistant Professor, Dept of EEE, Annamacharya Institute of Technology & Sciences, Rajampet, India

<sup>2</sup>Assistant Professor, Dept of EEE, Annamacharya Institute of Technology & Sciences, Rajampet, India

<sup>3</sup>PG Student, Dept of EEE, Annamacharya Institute of Technology & Sciences, Rajampet, India

---

**Abstract:-** The solar power plants are more reliable, comparing to the other plants, because no fuel and reduced CO<sub>2</sub> emission. But the solar power generation system do not work in all weather conditions, it is power generated only solar radiation time and initial cost is very high. To overcome this problem by using fuel cell (FC). In fuel cell power generation there will be no problems, where as in fuel cell power distribution systems have some problems like overloading the distribution feeders. In this project to overcome this overloading by using Loop Power Controller (LPC). The loop power controller to control real power and reactive power flow by adjusting voltage ratio and phase shift. Daily loading unbalance is determined by analyzing fuel cell (FC) power generation recording by using SCADA system and load profile based on Data Automation System (DAS). The loop power controller can improve controllability, operational flexibility and reduce power loss of the distribution system. The Loop Power Controller (LPC) is based on the MATLAB/ SIMULINK software.

---

### **I. INTRODUCTION**

The fuel cell, wind turbines, hydrogen turbines and photovoltaic arrays are environmental friendly. This type of generations rapidly increasing around the world because they can increase the demand of electric power and to decrease the green house gases. In this electrical power generation plants having outstanding advance power electronics and energy storage devices for transient back up have accelerated penetration of the distribution generation system. The electrochemical device is called fuel cell it is convert chemical energy to electric energy. However, batteries need to be placed in parallel or series with the fuel cell as a temporary energy storage elements to support start up or sudden load variations why because the fuel cell cannot respond sudden load changes. A fuel cell by definition is an electrical cell, which unlike storage cells can be continuously fed with a fuel so that the electrical power output is sustained indefinitely (Connihan, 1981). They convert hydrogen, or hydrogen-containing fuels, directly into electrical energy plus heat through the electrochemical reaction of hydrogen and oxygen into water. The process is that of electrolysis in reverse. In the summer peak period the load balance is critical, because of over loading problem at this time by usage of air condition is more. Loading balance is also important for both schedule outages and service restoration after fault isolation to perform load transfer between distribution feeders. The load varies from time to time in the feeder, it will make it very difficult to find the desire load balance by using network configuration in system planning stage. The renewable distributed generation like wind power, fuel cell power and photovoltaic power being installed in distribution feeders, the injection of intermittent power generation more of challenge to achieve load balance of distribution system. The design of the LPC control strategy must consider intermittent power injection by FC generation and varying feeder loading so that the loading unbalance and system power loss can be minimized in each study hour. This paper is organized as follows. First, Section II introduces the distribution automation system with a loop power controller. Section III the impact of the FC system on feeder loading balance and loss reduction of the distribution system is investigated. In Section IV, presents the feeder loading balance simulation and LPC control algorithm. Section V Loading Balance of Distribution Feeder by LPC and loss analysis, section VII, gives conclusions.

### **II. ANALYSIS OF FUEL CELL (FC)**

A fuel cell is an electrochemical cell that converts a source fuel into an electrical current. It generates electricity inside a cell through reactions between a fuel and an oxidant, triggered in the presence of an electrolyte.

The reactants flow into the cell, and the reaction products flow out of it, while the electrolyte remains within it. Fuel cells can operate continuously as long as the necessary reactant and oxidant flows are maintained. Fuel cells are different from conventional electrochemical cell batteries in that they consume reactant from an external source, which must be replenished [1] – a thermodynamically open system. By contrast, batteries store electrical energy chemically and hence represent a thermodynamically closed system. Many combinations of fuels and oxidants are possible. A hydrogen fuel cell uses hydrogen as its fuel and oxygen (usually from air) as

---

its oxidant. Other fuels include hydrocarbons and alcohols. Other oxidants include chlorine and chlorine dioxide Fuel cells come in many varieties; however, they all work in the same general manner. They are made up of three segments which are sandwiched together: the anode, the electrolyte, and the cathode. Two chemical reactions occur at the interfaces of the three different segments. The net result of the two reactions is that fuel is consumed, water or carbon dioxide is created, and an electrical current is created, which can be used to power electrical devices, normally referred to as the load. At the anode a catalyst oxidizes the fuel, usually hydrogen, turning the fuel into a positively charged ion and a negatively charged electron. The electrolyte is a substance specifically designed so ions can pass through it, but the electrons cannot. The freed electrons travel through a wire creating the electrical current. The ions travel through the electrolyte to the cathode. Once reaching the cathode, the ions are reunited with the electrons and the two react with a third chemical, usually oxygen, to create water or carbon dioxide.

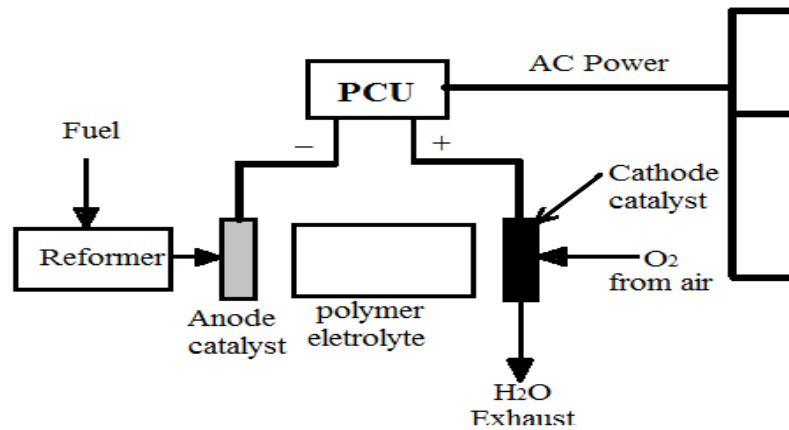

Fig.1 Configuration of Fuel Cell

The configuration of fuel cell as shown in fig 1. The fuel cell plants consist of three main parts stack, reformer and power conditioning unit (PCU). First, reformer produce hydrogen gas from fuels after then provider it for the stack. Second, this stack has main unit cells in series, to generate higher voltage needed for their applications because a single cell that consist of electrolyte. The PCU include power converters convert a low voltage DC from the fuel cell to a high sinusoidal AC voltage.

**A. DYNAMICS OF REFORMER**

For dynamic modeling of the fuel cells, the reformer and stack, which determine the dynamic response of the fuel cell system, are further described. Fig 2 shows a detailed block diagram of the fuel cell system to illustrate its operation.

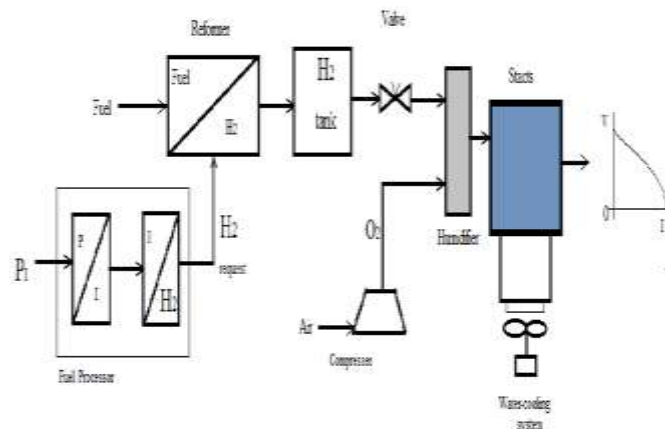

Fig. 2 Block Diagram of Fuel Cell

As depicted in Fig. 1, the fuel cell system consists of fuel cell stack and auxiliary systems such as a fuel cell processor to request the hydrogen gas, a reformer, an air compressor to provide pressurized oxygen flow

through the cathode, a valve to control the hydrogen flow through the anode, a humidifier to add moisture to the hydrogen and oxygen gases, and a water-cooling system to remove heat from the stack.

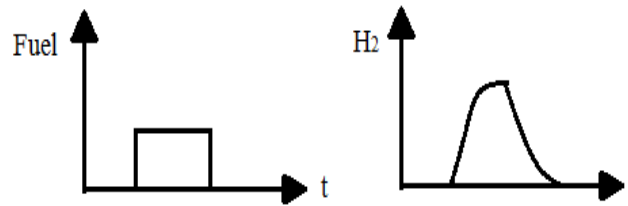

Fig.3 Dynamic Model of The Reformer

**B. CASE STUDY OF FUEL CELLS SYSTEM**

Below figure shows the one-line diagram of the power system in the stadium. There are 179 units of DC/AC inverters which are used to convert the solar panel generation to 380 Vac besides serving the local loads in the fuel cell generation. The daily power generation of the study fuel cell has been recorded by the SCADA system as shown in Fig.

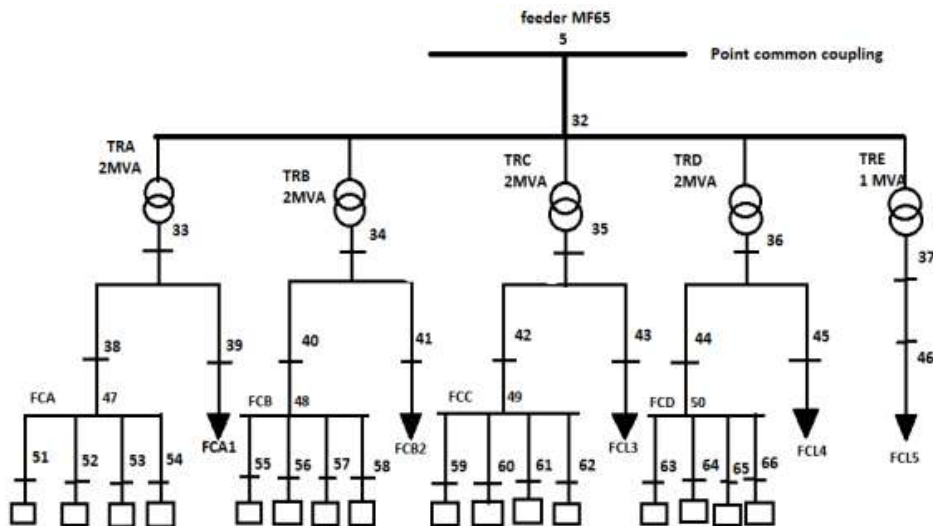

Fig.4 One Line Diagram of Fuel Cell System

**III. LOOP POWER CONTROLLER IN DISTRIBUTION AUTOMATION SYSTEM**

The distribution automation system (DAS) as shown in fig , its take to reference from power station. The DAS consists master station (MS) with software application, remote terminal unit (RTU) and feeder terminal unit (FTU) in substation. The distribution feeders are connected as open loop configuration with one of the automatic line switches selected the open tie switch. In open loop configuration feeder having circuit breaker, when fault occurs in feeder the circuit breaker will be trips, the over current fault flags of all upstream FTUs are set due to large fault currents, after the all fault flags are received in master station. The master station sends command to open all line switches by using the open tie switches around the faulted location, after clearing the faults the feeder has to be recloses. In DAS fault restoration effectively in power, but balance of loading is difficult in distribution system because the switching operation is required too frequently, to overcome the problem we are proposing the LPC, it is applied to replace open tie switch by adaptive power flow control for load transfer. The advantages of LPC in distribution feeder pair, 1) reduce the voltage fluctuations with fast compensate the reactive power. 2) The real power and reactive power is controlled. 3) In the distribution system controllability operation flexibility is improved. 4) Reduced power system losses with improved load balance of distribution system.

**IV. LPC CONTROL MODEL**

The LPC control of load transfer to derive voltage ratio and phase shift, the LPC equivalent circuit model is proposed by considering the branch impedance of distribution feeder for the simulation of feeder load balance. The overall process to derive the LPC control algorithm as shown in fig.6.

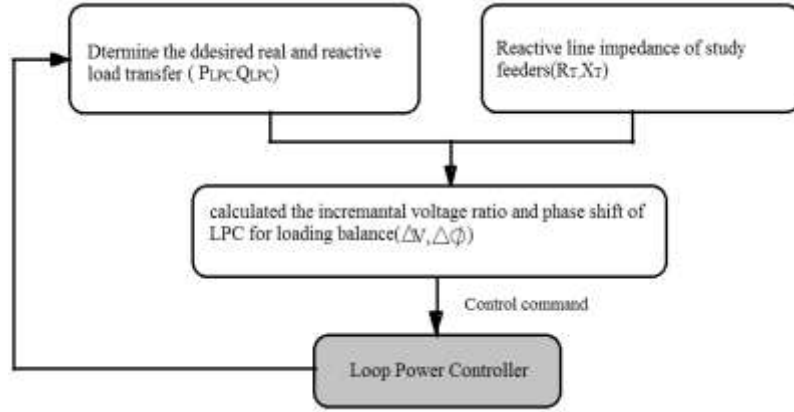

Fig.6 Flow Chart of LPC Algorithm

### A. SIMULATION OF FEEDER LOADING BALANCE

The circuit model of LPC considers as the combination of phase shifter and tap changer has shown in fig IV(c). By adjusting voltage ratio phase shift between both sides of LPC, according to the branch impedance and loading unbalance of distribution feeders. LPC can be controlled real power and reactive power to achieve the load balance. The ideal transformer having the equivalent circuit model with turn ratio of  $1:n\angle\phi$ . Mainly to derive the voltage ratio and phase shift of LPC.

$$\begin{pmatrix} \bar{I}_s \\ \bar{I}_r \end{pmatrix} = \begin{pmatrix} |n|^2 \bar{y} & -n^* \bar{y} \\ -n \bar{y} & \bar{y} \end{pmatrix} \begin{pmatrix} \bar{V}_s \\ \bar{V}_r \end{pmatrix}$$

Where  $n = n e^{j\phi}$ .

$$\bar{I}_s = n^2 \bar{y} \bar{V}_s - n \bar{y} \bar{V}_r$$

$$\bar{I}_r = n^2 \bar{y} \bar{V}_s + \bar{y} \bar{V}_r$$

$$= (1-n) \bar{y} \bar{V}_s + \bar{y} (\bar{V}_r - \bar{V}_s)$$

$$d\bar{I}_s' = -(n^2-1) \bar{y} \bar{V}_s - (1-n) \bar{y} \bar{V}_r$$

$$d\bar{I}_r' = (1-n) \bar{y} \bar{V}_s$$

$$\bar{I}_s = \bar{y} \bar{V}_s - \bar{y} \bar{V}_r e^{-j\phi}$$

$$= (1-e^{-j\phi}) \bar{y} \bar{V}_r + \bar{y} (\bar{V}_s - \bar{V}_r)$$

$$\bar{I}_r = (1-e^{j\phi}) \bar{y} \bar{V}_s + \bar{y} (\bar{V}_r - \bar{V}_s)$$

$$d\bar{I}_s'' = -(1-e^{-j\phi}) \bar{y} \bar{V}_r$$

$$d\bar{I}_r'' = -(1-e^{j\phi}) \bar{y} \bar{V}_s$$

$$d\bar{I}_s = d\bar{I}_s' + d\bar{I}_s''$$

$$d\bar{I}_r = d\bar{I}_r' = d\bar{I}_r''$$

$$\begin{bmatrix} d\bar{I}_s \\ d\bar{I}_r \end{bmatrix} = \begin{pmatrix} (1-n^2) \bar{y} & (n+e^{-j\phi}-2) \bar{y} \\ (n-1) \bar{y} & (n+e^{j\phi}-2) \bar{y} \end{pmatrix} \begin{pmatrix} \bar{V}_s \\ \bar{V}_r \end{pmatrix}$$

$$P_{LPC} = \frac{(P_1 - P_2)}{2}$$

$$Q_{LPC} = \frac{(Q_1 - Q_2)}{2}$$

$$R_t = R_1 + R_2$$

$$X_t = X_1 + X_2$$

$$\Delta\phi = \tan^{-1} \frac{P_{LPC} X_t - Q_{LPC} R_t}{1 + P_{LPC} R_t + Q_{LPC} X_t}$$

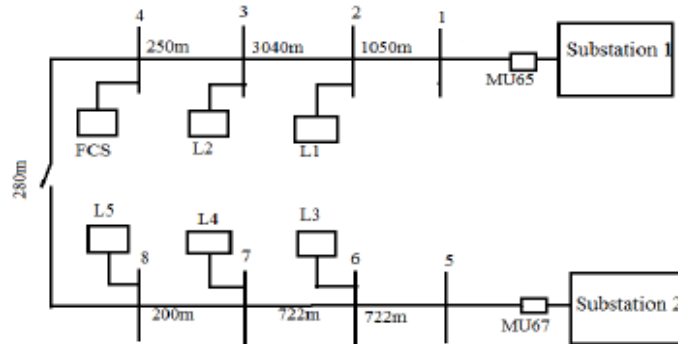

Fig.7 Distribution feeders for simulation

5. LOADING BALANCE AND LOSS ANALYSIS USING LPC IN AND DISTRIBUTION FEEDER

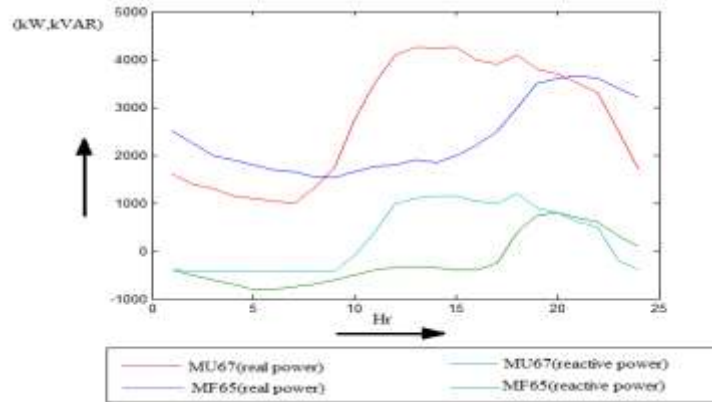

Fig. 8 Power Profiles of Feeders MF65 and MU67 without FC

The loading balance of distribution feeders to adjust voltage ratio and phase shift between both feeders by using LPC and the injection FC power, the LPC assumed to be installed replacing the open tie switches between feeder MF65 and MU67 as shown in fig V(a). The daily load profile of real power and reactive power loading of feeders MF65 and MU67 and the FC power injection is not considered, in the feeder MF65 peak load was 3724 kW/1232 kVAR at 8pm and feeder MU67 peak load was 4483 kW/1485 kVAR at 2pm

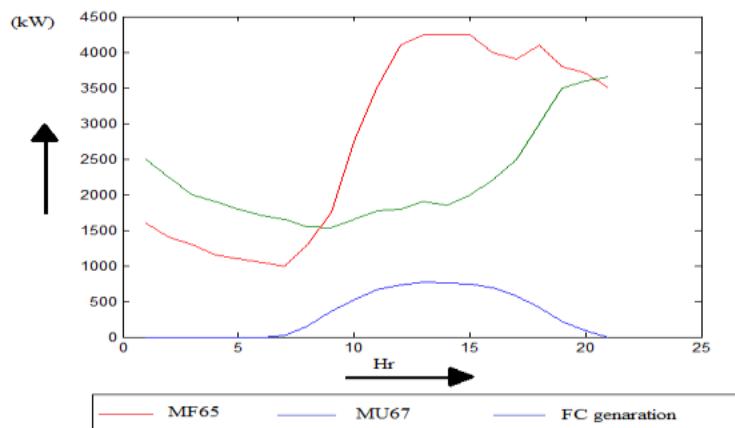

Fig. 9 Power profiles of feeder MF65 and MU67 with FC

After execution the real power and reactive power load profile of two feeders without injection FC power as shown in fig V(c), the distribution feeders to achieve the load balance using LPC only, the real power and reactive power difference between feeder MF65 and MU67 to be reduced from 1864

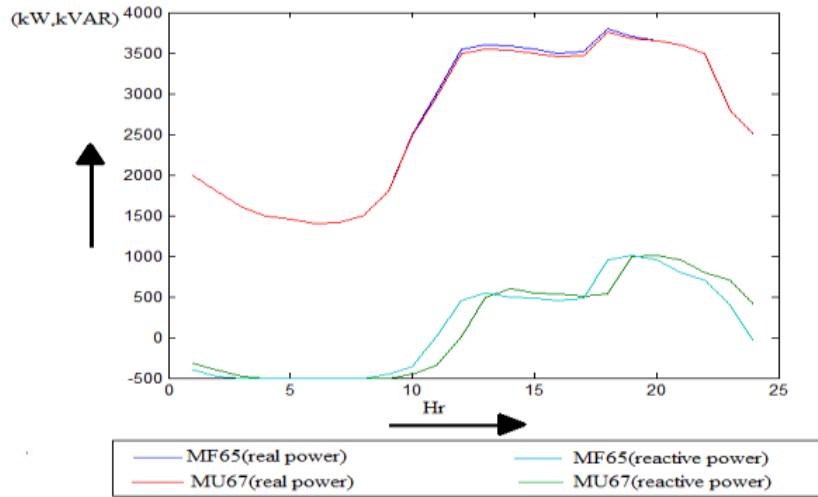

Fig.9 Loading Balance of Both Feeders with LPC

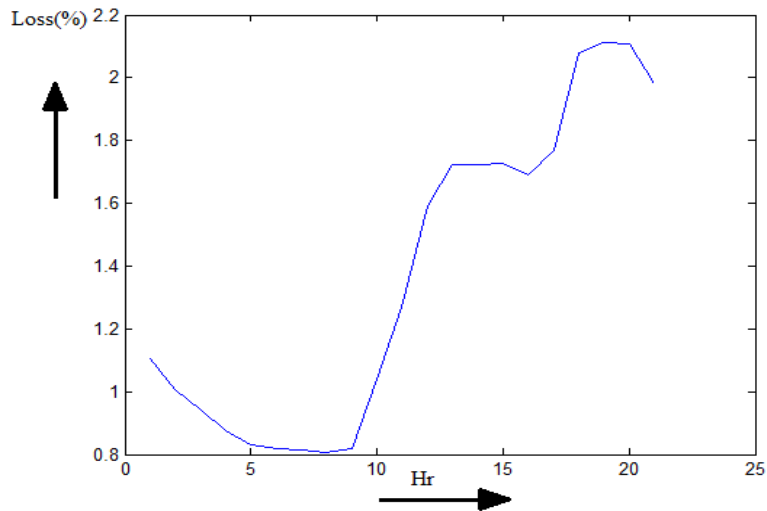

Fig.10 Power Loss before Applying LPC with FC

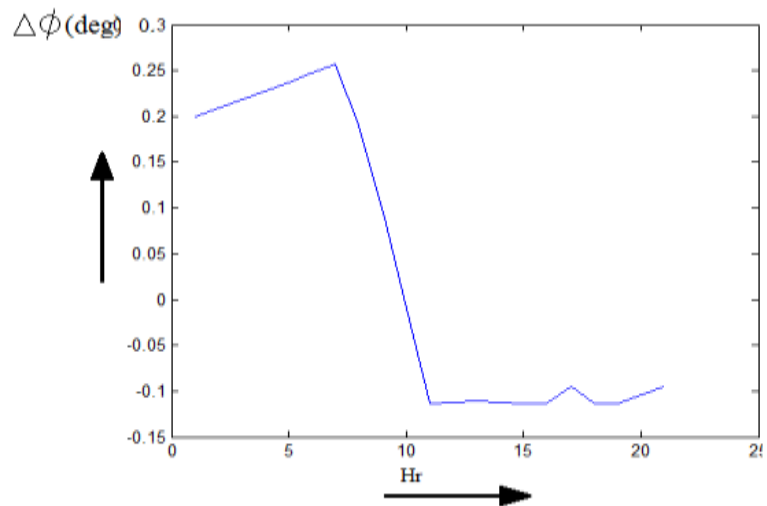

Fig.15 System Power Loss after Applying LPC with FC

## VI. CONCLUSION

The daily unbalanced loads are recorded by the SCADA, the distribution system consisting of two feeders with FC system has been selected for computer simulation. In LPC has to applying the control algorithm to adjust the voltage ratio and phase shift between two feeders. Finally the conclusion of this paper load balance of distribution system with intermitting FC power generation to be obtained effectively by the LPC implementation. Loading balance by using LPC and FC power in distribution system is also reduced the power loss has to be fined in this paper, the loss reduction is more effectively intermitting FC power generation comparing photo voltaic generation.

## REFERENCES

- [1]. Jin-Woo Jung,<sup>1</sup> Ali Keyhani,<sup>2</sup> Modeling and Control of Fuel Cell Based Distributed Generation Systems in a Standalone AC Power Supply
- [2]. Y. Zhu and K. Tomsovic, "Adaptive power flow method for distribution systems with dispersed generation," *IEEE Trans. Power Del.*, vol. 17, no. 3, pp. 822–827, Jul. 2002.
- [3]. 2008 Report of Long-Term Load Forecasting and Energy Development, Bureau of Energy, Ministry of Economic Affairs, Taiwan, Dec. 2008.
- [4]. N. Okada, "A method to determine the distributed control setting of looping devices for active distribution systems," in *Proc. 2009 IEEE Bucharest Power Tech (POWERTECH)*, Bucharest, Romania, Jun. 2009, pp. 1–6.
- [5]. S. A. Farouji, E. Bakhshizadeh, R. Kazemzadeh, and R. Ghazi, "The static VAR compensator equations development for loading balance at desired power factor based on load admittance parameters and instantaneous voltage and current values," in *Proc. 2009 Int. Conf. Elect. Power Energy Conversion Syst.*, Sharjah, United Arab Emirates, Nov. 10–12, 2009, pp. 1–6.
- [6]. C. H. Lin, "Distribution network reconfiguration for loading balance with a coloured petri net algorithm," *Proc. Inst. Elect. Eng., Gen., Transm., Distrib.*, vol. 150, no. 3, pp. 317–324, May 2003.
- [7]. N. Okada, "Verification of control method for a loop distribution system using loop power flow controller," in *Proc. 2006 IEEE PES Power Syst. Conf. Expo.*, Atlanta, GA, Oct./Nov. 2006, pp. 2116–2123.