

# Simulation of Adaptive Fuzzy PI Speed Control for Centrifugal Machine

Ratna Ika Putri<sup>1</sup>, Mila Fauziyah<sup>2</sup>, Agus Setiawan<sup>3</sup>  
<sup>1,2,3</sup>Faculty of Electrical Engineering, Malang State Polytechnic, Indonesia

**Abstract:**—In the sugar factory, centrifugal machine plays an important part in the process of centrifugation to separate the molasses and sugar crystal. Centrifugal machine driven by induction motor which has a non-linear characteristics. The load changes on the induction motor will cause the motor speed change. While the centrifugal machine, load changes vary widely. So it takes the controller to maintain the speed according to the reference. The aim of this paper is to design an adaptive fuzzy PI controller for centrifugal machine speed control that can maintain speed according to reference speed although upon the load and reference change. Simulation of adaptive fuzzy PI controller using Matlab / Simulink will be discussed

**Keyword:**—Controller, Adaptive Fuzzy PI, Centrifugal machine, induction motor

## I. INTRODUCTION

Sugar cooking process consists of several processes, one of which is a centrifugation process plays an important part in determining the quality of sugar [1]. Loss of sugar can occur at each cooking station especially on crystallization and centrifugation station so that it can affect the quality of sugar are produced. The Centrifugation process aims to separate massacuites into crystal sugar and molasses by using centrifugal machine. Centrifugal machine uses the principle of centrifugal force and spin motor. With a suitable speed of centrifuge will suppressed loss of crystal sugar in the molasses.

Drive of centrifugal machine are induction motors where it's has non linear characteristic especially rotor resistance whose value varies with operating conditions, so that the load change will cause change in the speed motor. The load change very varies as result of different massacuites quality and separation of molasses and sugar crystals will cause reference speed can not to be maintained. Decrease the speed of rotation will increase the loss of sugar in this process so that it will reduce the productivity and sugar quality. Therefore we need a controller that can maintain the motor speed despite varying load changes. With the speed setting centrifuges, though it varies massacuite input and low sugarcane quality then the speed motor will remain. So time of centrifugation process is shorter and the high quality of crystal sugar will be achieved. If this can be achieved then the loss of sugar through molasses on centrifugation process can be reduced and productivity can be improved

The design of the controller to adjust the speed of the motor can be done by several methods. Using fuzzy adaptive learning algorithm as a 3 phase induction motor controller produces better performance compared with the PID controller, but the fuzzy adaptive controller is highly dependent on the human expert as a teacher in learning [2]. PI and the conventional PID controller has the advantage of being very effective in control the steady state error and easy to implement but the performance of controller is highly dependent on the determination of the parameters [3]. Based on [4], apply fuzzy logic controller to regulate the speed of an induction motor. Fuzzy logic controller combined with PI where PI parameters to input variables of fuzzy logic. From the simulation results, the fuzzy controller is able to produce maximum torque speed range is set and at steady state conditions, the efficiency of an induction motor can be increased. PI controller tuning using methods PSO (Particle Swarm Optimization) to control the speed of induction motor [5]. Compared with the fuzzy logic controller and PI controller without tuning, the conventional PI controller produces zero steady-state error while the fuzzy logic produces no overshoot and undershoot. Tuning controllers with Pi produces better performance, especially on the parameters that the system transient response rise time, overshoot, undershoot and settling time. In this paper will used PI Fuzzy Adaptive as controller to regulate centrifugal machine speed. Fuzzy controller is used to tune the parameters  $K_p$  and  $K_i$  of PI so that the controller can keep up with centrifuge changes load and the constan speed can be achieved.

## II. MODELLING CENTRIFUGAL MACHINE

Centrifugal machine control system consists of a PC Pentium dual-core, DSP board, inverter, induction motors, centrifuges chamber and tachogenerator as shown in Fig 1. PC contains the control algorithms, the DSP board that serves to connect the PC to the inverter and the inverter function to drive the induction motor. In this paper the strejc method used to identify centrifuges system. Strejc method is an approach to identify the response of the plant in order to get the model plant is based on the transient response of the system [6]. The use of methods strejc requires precision in drawing a tangent to the transient response for the transfer function of the system parameters

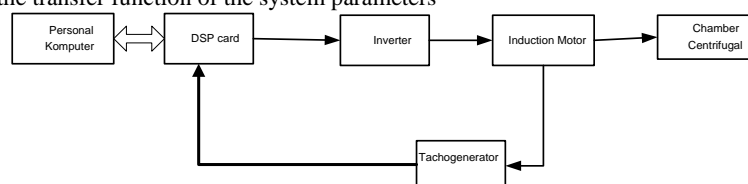

Fig 1. System Diagram Block

Table 1. Strejc Table

<b>n</b>	<b>Ta / □</b>	<b>Tu / □</b>	<b>Tu/ Ta</b>
2	2,7183	0,2817	0,1036
3	3,6945	0,8055	0,218
4	4,4635	1,4254	0,3194
5	5,1186	2,102	0,4103
6	5,6991	2,8113	0,4993
7	6,2256	3,5489	0,57
8	6,7113	4,3069	0,6417
9	7,164	5,081	0,7092
10	7,5898	5,8685	0,7732
11	7,993	6,6673	0,8341

Accordingly to Strejc, a non-periodic system with  $n$  different time constants can be approximated by a transfer function that represents  $n$  identical time constants, i. e.:

$$G(s) = K \frac{e^{-\tau s}}{(Ts+1)^n} \quad (1)$$

where  $K$  represents the stationary state gain. The identification problem is then reduced to estimate the parameters  $\tau$  and  $n$  [6]. By using Taylor series approximation and table of strejc, characteristic roots can be calculated as follows:

- a. To order  $n = 1$ , the maximum degree of the numerator is zero order

$$G(s) = K \frac{e^{-\tau s}}{(Ts+1)^1}$$

- b. To order  $n = 2$ , the maximum degree of the numerator is first order

$$G(s) = K \frac{\tau e^{-\tau s} S + e^{-\tau s}}{(Ts+1)^2}$$

- c. To order  $n = 3$ , the maximum degree of the numerator is second order

$$G(s) = K \frac{\frac{\tau}{2} e^{-\tau s} S^2 + \tau e^{-\tau s} S + e^{-\tau s}}{(Ts+1)^3}$$

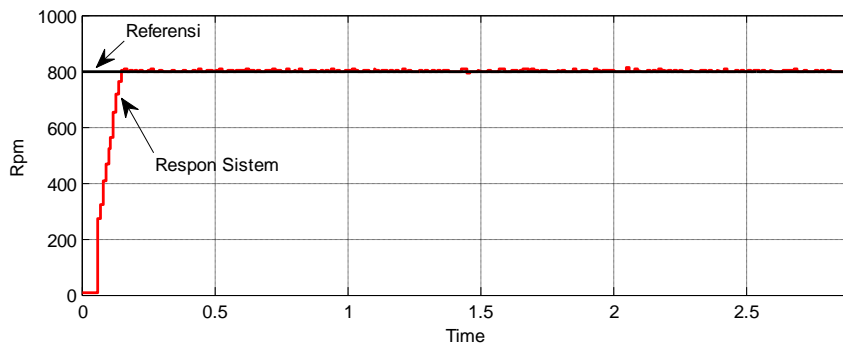

**Fig 2.** Unit Step Response of Centrifugal Machine

According to the table strejc, parameters can be determined based on the value of  $Tu$  and  $Ta$  were obtained from the open-loop system response graph as shown in Fig. 2. Order plant can be determined by the following equation

$$n = Tu/Ta$$

$$\tau = Tu - Tu' \text{ dalam detik.}$$

Based on the response of the open loop system can be determined value of  $Tu$  by 0.06 second and  $Ta$  by 1.21 second, which is obtained from drawing tangents of plant open loop responses. Comparison between  $Tu$  and  $Ta$  values of 0.286 and the plant is of the order of 3. So that obtain the transfer function for the centrifugal machine is

$$G(s) = 1,282 \frac{0.006S^2 + 0.012S^2 + 0,78}{(0,000185S^3 + 0,00975S^2 + 0.171S + 1)}$$

### III. DESIGN ADAPTIVE FUZZY PI CONTROLLER

There are several methods of control that can be used to control the speed of the induction motor driving a centrifugal machine, among other conventional control methods are the controller proportional integral (PI), proportional integral differential (PID). This method is easy to implement and generate steady-state error is small and effective to control the error at steady state conditions but this method does not produce a good transient response [3]. The existence of the

integral parameters of PI controllers would result in steady state error is very small close to zero but when compared to the PID, PI controllers are slower reaches setpoint [7].

Nowadays modern control techniques have been developed based on artificial intelligent called intelligent control. One of these techniques is the fuzzy logic controller can be designed based on the human mindset. From the simulation results, the fuzzy controller is combined with PI result in good performance for induction motor speed control. [4]. In this paper, Adaptive fuzzy PI controller is used to regulate the speed of centrifuges. At the output of fuzzy logic controller is used to tune the PI parameters  $K_i$  and  $K_p$  according load changes occurs in centrifugal machine. Block diagram of adaptive fuzzy PI controller is shown in Fig 3. controller consists of two inputs, namely the delta error and error and the output is the control signal. Fuzzy logic has two inputs, namely the delta error and error and also has two outputs, namely  $K_i$  and  $K_p$  which becomes the input to the PI controller.

PI controller consists of parameters  $K_i$  and  $K_p$  parameters are tuned by fuzzy logic. Any load changes then  $K_p$  and  $K_i$  expenses will change following it. The output of the PI controller is a control signal to drive the inverter which directly drive the induction motor to rotate the centrifugal chamber. PI controller output can be expressed by the following equation

$$V_{out} = K_p.e(t) + K_i \int e(t) dt \quad (2)$$

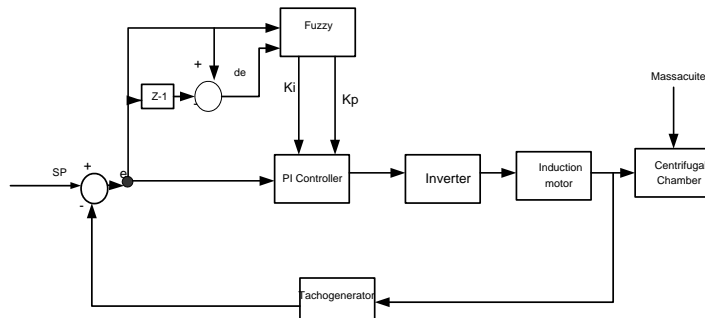
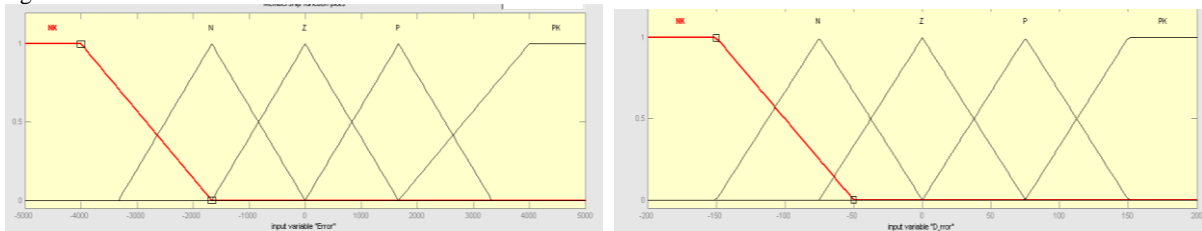
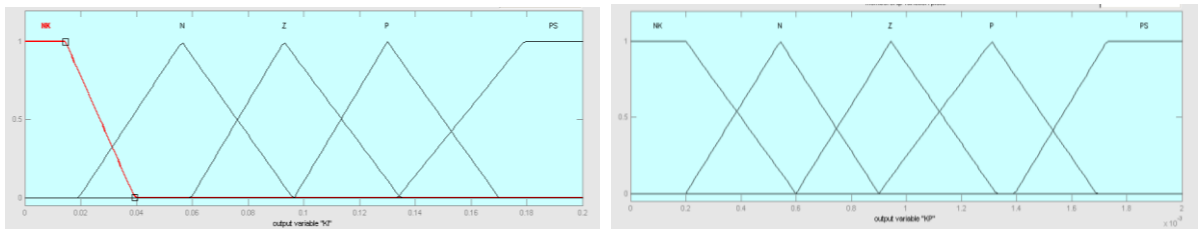

Fig 3. Adaptif Fuzzy PI Speed Controller

The fuzzy controller block has two input variable and two output variable. Input variable consist of error and change of error. Error obtained from difference between actual and reference speed. Input variable of Error and change of error has five membership function in the form of trapezium and triangular there are Very Negative (NK), Negative (N), Zero (Z), Positive (P), and Very Positive (PK) as shown on Fig. 4. Output variable consist of  $K_p$  and  $K_i$  which has five membership function too. There Very Negative (NK), Negative (N), Zero, Positive (P), and Very Positive (PS) is shown on Fig.5. On this design the fuzzy rule base on area and heuristic for control signal as shown Table 2 for  $K_p$  and Table 3 for  $K_i$  output signal.



(a). Input variable of Error (b). Input Variable of change of Error  
Fig. 4 Fuzzy Membership Function for Input Variable



(a). KI (b) KP  
Fig.5 Fuzzy Membership Function of Output Variable

Table 2. Fuzzy Rule of KP

e Δe	NK	N	Z	P	PK
NK	PS	PS	P	P	Z
N	PS	P	P	Z	N
Z	PS	P	Z	N	NK
P	P	Z	N	N	NK
PK	Z	N	N	NK	NK

Table 3. Fuzzy Rule of KI

e Δe	NK	N	Z	P	PK
NK	NK	NK	N	N	Z
N	NK	N	N	Z	P
Z	NK	N	Z	P	PS
P	N	Z	P	P	PS
PK	Z	P	P	PS	PS

#### IV. SIMULATION ADAPTIF FUZZY PI CONTROLLER

Simulation Adaptive Fuzzy PI speed control for centrifugal machine using Simulink Matlab as shown in Fig. 6. The design of fuzzy uses fuzzy toolboxes which are available in Simulink. Defuzzification uses the centroid method and membership functions use trapezium and triangular shapes. The plant is designed by transfer function in Simulink block using the model equation determined by the Strejc method. Simulink block for PI controller as shown in Fig. 7. In this paper, the output variable of fuzzy is used to tune the PI parameter which drives the induction motor. Simulation is done with load change, reference speed change, and no-load condition to determine the performance of the adaptive fuzzy PI controller.

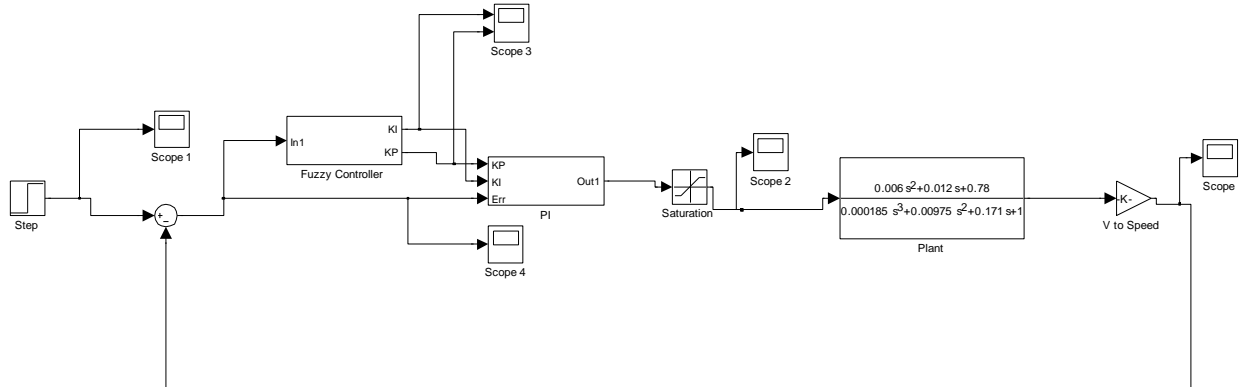

Fig. 7 Block Simulink Matlab For Adaptive Fuzzy PI Speed Control

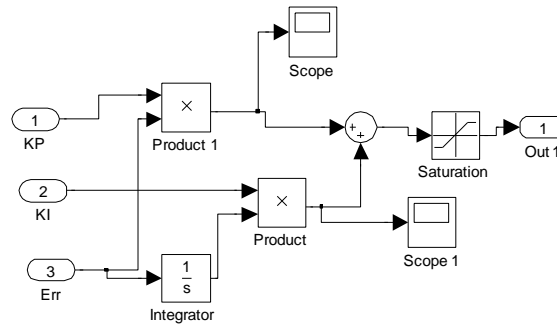
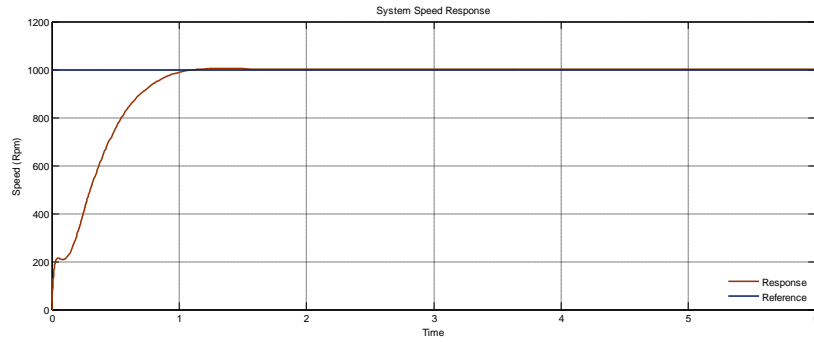

Fig. 8 Block Simulink of PI Controller

#### V. RESULT AND DISCUSSION

Based on the simulation results, it will get the response speed of the system and the output signal of the adaptive fuzzy PI controller. Fig. 8 shows the response speed and the output signal of the controller when not loaded. By providing a reference speed of 1000 rpm, the controller produces an output signal of 3,357 V so that the system will generate the appropriate speed reference. The output controller will drive the inverter to turn the motor, which rotates the centrifugal chamber. The response speed of the system has an overshoot of 0.5% with a settling time of 1,051 sec and a steady state error of 0.026%.



(a) System Speed Response

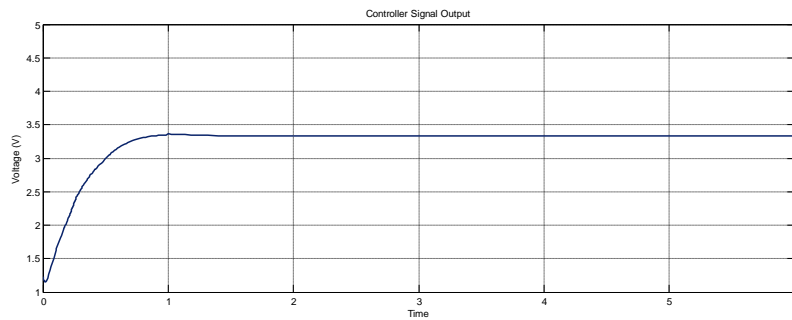

(b) Output Signal Controller

**Fig.9** System Speed Response of Adaptive Fuzzy PI Controller Without Load

In the operation of the sugar centrifugal machine need speed changes, especially when charging massacuite into the chamber and the round process. Fig 10 shows the response speed of the system and the controller output signal is given at the reference speed changes. In the system given three times the speed reference of change and the adaptive fuzzy controller can follow the reference change by providing appropriate control signals change.

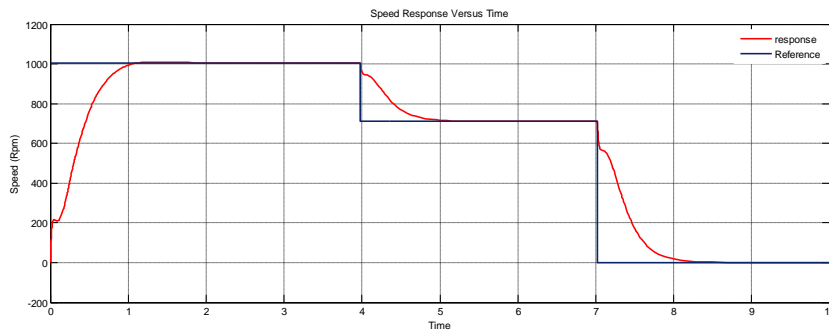

(a) System Speed Response

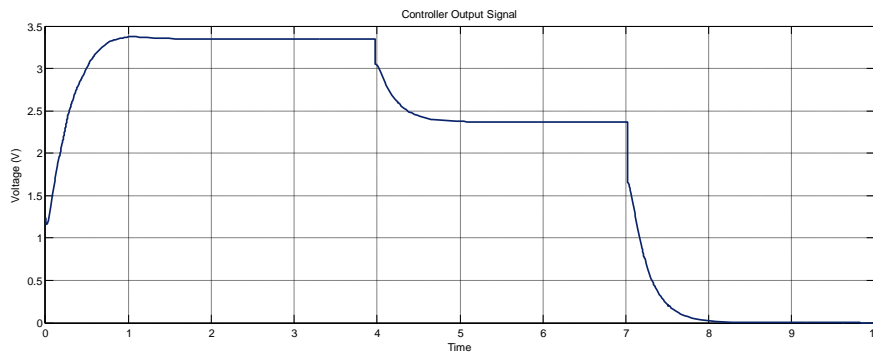

(b) Output Signal Controller

**Fig. 10** System Speed Response of Adaptive Fuzzy PI Controller With Reference Variations

The process of separation of molasses and sugar crystals will cause the changes in the load so that the load change on the sugar centrifugal machine varied. Besides it, the quality of massacuites the included also greatly affect the load on the system. Based on the simulation by providing the load changes, the controller can maintain the speed according to the reference as shown Fig.11. The controller can recognize load changes and generates the appropriate output signal so that the reference voltage can be maintained.

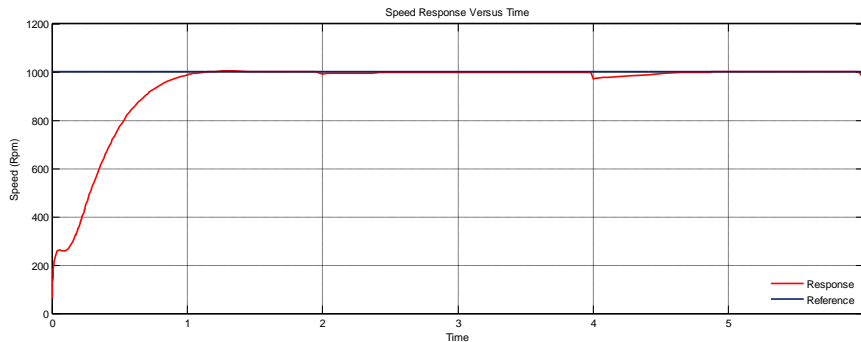

(a) System Speed Response

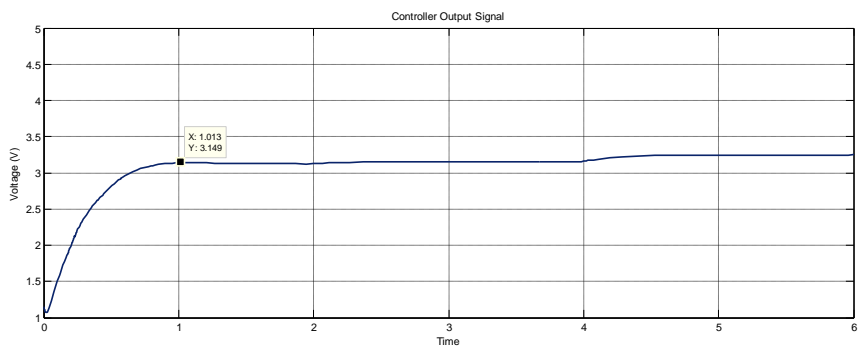

(b) Output Signal Controller

**Fig.11** System Speed Response of Adaptive Fuzzy PI Controller With Load Change

## VI. CONCLUSION

This paper has presented Adaptive fuzzy PI for speed control of induction motor on centrifugal machine. Applications of adaptive fuzzy PI speed controller shown a good performance. Centrifugal system modeled by strejc method. The system was analyzed and designed, and performance was studied by simulation with simulink matlab. The controller can maintain the speed according to reference despite load changes and it can follow the reference change that occurred.

## REFERENCES

- [1] Barbara Roge et.al., “Centrifugal Control and the Quality of White Sugar”. Symposium by Association Andrew VanHook. Maret 2004.
- [2] Ratna Ika Putri, “Implementation of adaptive Fuzzy on Three Phase Induction Motor Speed Control” Jurnal GELAGAR Vol 18 No.1 Universitas Muhammadiyah Solo. 2007.
- [3] Gasboui Brahim et.al. “Adaptive Fuzzy PI of Double Wheeled Electric Vehicle Drive Controlled by Direct Torque Control”. Leonardo Electronic Journal of Practices and Technologies. Issue 17. July-December 2010.
- [4] Chitra V & Prabhakar RS. “Induction Motor Speed Control Usingng Fuzzy Logic Controller”. World Academy Engineering and technology. 2006
- [5] Thangaraj Radha et.al. “Optimal gain Tuning of PI Speed Controller in Induction Motor Drives Using Particle Swarm Optimization”. Logic Journal of IGPL Advance Access. July 2010.
- [6] Ramirez & Aguado, 2002. “Control of Biomass Combustor Using The General Smith Predictor”, Journal of Applied Research And Technology.
- [7] Pundaleek BH et.al. “ Speed Control Of Induction Motor: Fuzzy Logic Controller v/s PI Controller”. International Journal Computer Science And Network Security. Oktober 2010
- [8] James C.P Chen & Chou Chung-Chi, “Cane Sugar Handbook, Manual For Cane Sugar Manufacturers And Their Chemists”, John Wiley, Singapore, 1993.
- [9] Zerikat, Benjebbar, Benouzza, “Dynamic Fuzzy-Neural Controller For Induction Motor Drive”, Proceedings of World Academy of Science, Engineering And Technology, Vol 10 Desember 2005
- [10] Urbanick Jean & Ravaux Bernard, *Discontinuos Centrifugal Machine Which is Intended, In Particular, To Separate Molassess from Crystal Sugar In Massacuite*, International Application Published Under The Patent Cooperation Treaty (PCT), 2007.