

# Influence of Switching Elements on Harmonics and Power Factor Improvement

<sup>1</sup>A.Kumar, <sup>2</sup>Dr.G.R.Gurumurthy  
B N M Institute of Technology, BSK  
2<sup>nd</sup> stage, Bangalore, India - 560070

**Abstract:-** Increasing demand for electrical energy by utilities has necessitated efficient utilization of available power. Most of the loads in the industry and domestic applications are inductive in nature causing a lagging power factor. This causes a reduction in the utilization of the power input. For the same power input the utilization can be improved by improving the power factor. Further the presence of harmonics results in poor quality of the power leading to losses. . In present days, solid state electronics control electric motors are frequently used for drive control (speed and torque). This can introduce harmonics in current and voltages. The general opinion among technologists is that improvement in power factor reduces losses in an electrical system. Although this is true in a general way, it is not so in systems which use switched electronic devices that can introduce large amount of harmonics [1].

The present work is aimed to study the effect of power factor correction on circuits consisting of power semiconductor switching. Boost convertor supplied from an unregulated supply was considered for the analysis of a static loading. The work also involved study of power factor improvement(PFI) for dynamic load. An automatic power factor controller was designed and implemented induction motor load. The controller was designed to sense the various parameters of the power and calculate the power factor. A rule-based table has been developed based on the power factor input. The controller can sense this power factor and automatically switch ON/OFF appropriate KVAR as per the programmed requirement. The results obtained are comparable with that reported in several previous work done.[1-6]

**Keywords:-** Power factor improvement, Harmonics, THD, APFC, Filters

---

## I. INTRODUCTION

Quantum of Energy generation is one of the metric for the measurement of a Nation's development. The requirement of energy is much more than the amount of power getting generated in developing countries like India. Under these circumstances Demand side management (DSM) is one of the methods to improve the utilization of energy. Most of the industrial and domestic loads are inductive in nature and hence the power factor of the loads are very poor. An improvement in the power factor results in availability of more active power for the same generated power. Power factor improvement is most commonly used in industrial units. Automatic power factor controllers (APFC) are equipped with semiconductor devices, switching of capacitor banks for the improvement of power factor. In present days, solid state electronics control for electric motors are frequently used for drive control (speed and torque). This can introduce harmonics in current and voltages. The general opinion among technologists is that improvement in power factor reduces losses in an electrical system. Although this is true in a general way, it is not so in systems which use switched electronic devices that can introduce large amount of harmonics.

### a. **Power factor:1. Concept of Power Factor**

Power factor is defined as the ratio of active power to apparent power. i.e.,  $PF = \frac{kw}{kva}$ . It is also defined as a cosine of the angle between voltage and current vectors in an electric network in which voltage and current are sinusoidal parameters. i.e.,  $PF = \cos \Phi$ , where  $\Phi$  is the angle between voltage and current vector. A poor power factor requires more apparent power for the same amount of active power consumed. It also increases the current level of operation and thereby increases losses in the system. A poor power factor is generally the result of inductive loads such as induction motor, welding set etc., The poor power factor can also be due to distortion in current waveform resulting from power electronic based converters like rectifier, inverter etc., used in the system.

## II. BENEFITS OF POWER FACTOR IMPROVEMENT

The benefits that can be achieved by applying the correct power factor correction are:

1. Reduction of power consumption due to improved energy efficiency. Reduced power consumption reduces green house emission and fossil fuel depletion.

2. Extra power is available from the existing supply due to reduction of consumption in reactive KVA.
3. Reduced  $I^2R$  losses in machines and hence efficiency increases.
4. Voltage regulation improves due to reduced voltage drop in long cables & long lines.
5. The current drawn for the same load is lesser hence KVA loading of the machines reduce.

The figure 1.1 shows the power triangle.

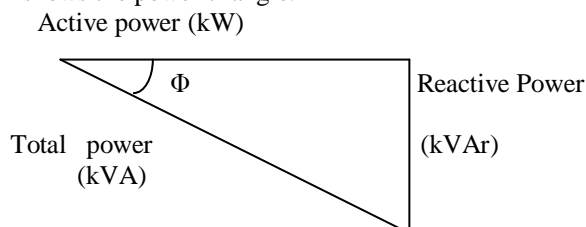

**Fig 1.1.** Power triangle

### III. POWER FACTOR IMPROVEMENT FOR INDUCTIVE LOADS

Power factor improvement is commonly adopted method for effective utilization of available power. The various advantages of improving power factor have been discussed earlier. The power factor improvement incorporates additional capacitive reactive power which compensates for the inductive reactive power of the load and thus improving power factor [1]. The vector diagram showing the improvement in power factor using capacitor bank is given in Fig.1.2

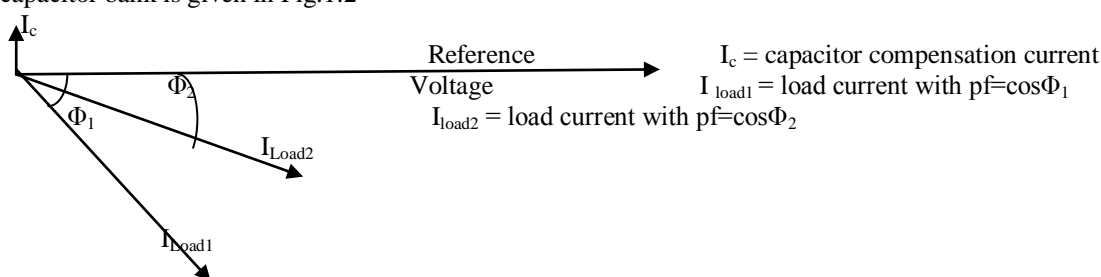

**Fig1.2:** Vector showing power factor improvement using capacitor bank.

KVA saving by improving power factor from  $\cos \Phi_1$  to  $\cos \Phi_2$  can be obtained as given in the expression below: saving in  $KVA = (KW / \cos \Phi_2) - (KW / \cos \Phi_1)$ . For improvement of power factor in large capacitive loads suitable inductors have to be used.

#### b. Harmonics:

Harmonics have existed for many years in the power lines of plants and factories. However only over the last decade they have turned into a major problem to normal operations. This is largely due to the proliferation of harmonic producing equipment and the increased sensitivity of certain types of equipment to harmonics. The effects of harmonics can often be serious - computer systems may fail to operate properly; capacitor banks, such as those used for power factor correction may fail prematurely (much before expected life). The presence of harmonics increases losses in the system.

### IV. CONCEPT OF HARMONICS:

Harmonics are distortions to the voltage and current waveforms from their normal sinusoidal shape. At the power generating stations, a 50 Hertz (Hz) sine wave is generated and distributed to a large number of residential and industrial loads. Certain types of loads distort the 50Hz wave by injecting additional signals of various magnitudes and frequencies. These additional signals are also sinusoidal in shape but their frequencies are multiples of the original waves for example, 150, 250 and 350Hz. These waves are called harmonics.

The frequency of the power systems parameter voltage and current waves are called the fundamental, which in our case is 50Hz. Harmonics are expressed as integral multiples of fundamental frequency i.e., 2<sup>nd</sup>, 3<sup>rd</sup>, 4<sup>th</sup>, 5<sup>th</sup> etc orders. An important feature of harmonics is that the magnitude of the harmonics normally decreases with increasing frequency. Thus, only the first few orders usually need to be considered in examining the effects of harmonics on power system components or equipment. Fig 1.3 shows a sample current wave with harmonics.

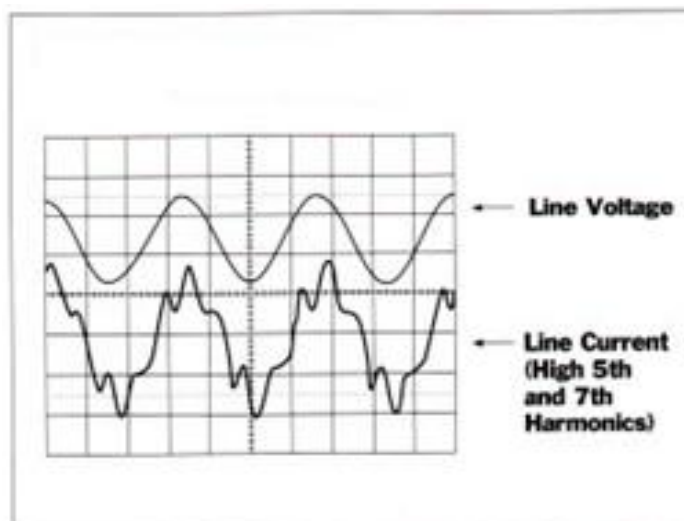

Fig 1.3. Waveform showing a sample of distorted current waveform due to harmonics.

### V. SOURCES OF HARMONICS:

The various sources of harmonics are discussed under:

1. Increase in use of Power converters which use controlled switching, such as rectifiers, inverters, and AC phase control systems has increased harmonics due to switching action.
2. Motors: Asymmetrical air gaps, slight irregularities in mounting axes can cause motors in equipment such as pumps, fans and compressors to produce harmonics.
3. APFC capacitors: Power Factor Correction Capacitors can magnify harmonics if not properly applied.

### VI. PFI IN AN UNCONTROLLED RECTIFIER WITH BOOST CONVERTER

#### a. Introduction and Design

An uncontrolled single phase rectifier supplying a boost converter with duty cycle of 50% and 90% was considered for investigation. The basic circuit used is given in Fig 2.1. For the design of the rectifier a ripple factor of 1% was considered.

Considering the frequency of 50hz and  $C_F = 250\mu\text{F}$  we get,

The ac input applied was 230v, 50Hz. The output of the rectifier was a DC of 325 V with 1% ripple. The boost converter was designed with a switch at 50% Duty cycle(D). Therefore the expected output voltage is  $V_o = V_S / (1 - D) = 325 / 0.5 = 650\text{V}$ . Also the boost converter was designed with a switch at 90% Duty cycle(D). Therefore the expected output voltage is  $V_o = V_S / (1 - D) = 325 / 0.1 = 3.25\text{kV}$ .

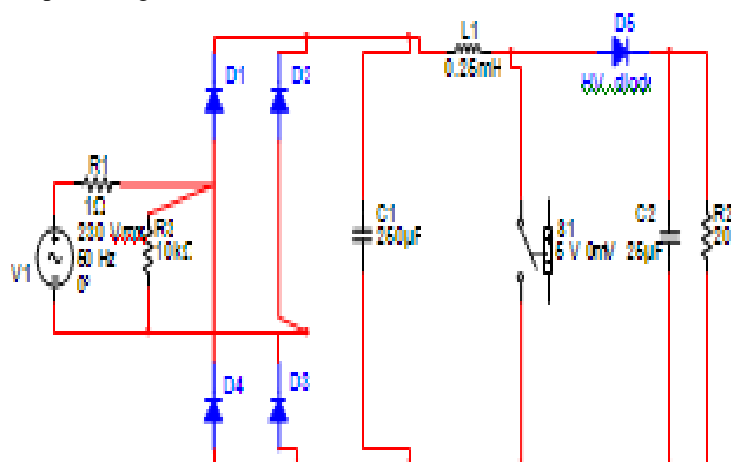

Fig 2.1 Uncontrolled rectifier with Boost converter.

The investigations were carried out using ORCAD PSpice Version 16.0 for duty cycle of 50% for the buck converter. From the waveform of input current, the harmonic components and THD were estimated. The

phase angle between fundamental components of voltages and current was considered as the power factor angle. Using the actual current waveform, the power losses were determined.

**b. Results:**

Initial investigations were carried out for duty cycle of 50% with and without any harmonic filter. Subsequently, simulations were carried out with duty cycle as 90% as per the circuit in Fig 2.2.

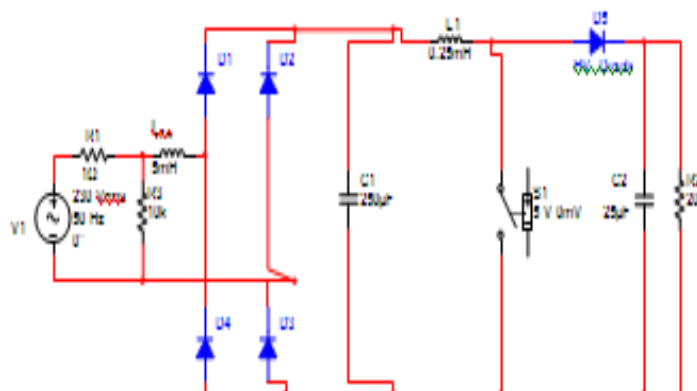

**Fig 2.2** Uncontrolled rectifier with Boost converter with series reactors

The results obtained are tabulated below. Table 2.1 shows the results obtained by considering a series reactor. Losses were calculated as  $P_{in} - P_o$

**Table 2.1.** Boost converter with series reactor in series with the supply (DC = 50%)

Sl No.	V <sub>DC</sub> (V)	L <sub>se</sub> (mH)	pf	P <sub>in</sub> watt	P <sub>o</sub> watt	I <sub>THD</sub> in %	Loss (w)
1	632	0	0.71	5500	3300	40.3	2200
2	632	0.1	0.71	5500	3400	40.1	2100
3	632	0.5	0.72	5800	3480	40.6	2320
4	632	1	0.74	6000	3600	39.1	2400
5	632	3	0.83	7500	4700	39	2800
6	632	5	0.91	8200	5000	38.9	3200
7	632	7	0.96	8200	4880	38.6	3320

**Table 2.2** shows the results obtained by considering a 90% duty cycle. Losses were calculated as  $P_{in} - P_o$

**Table 2.2.** Boost converter with series reactor filter in series with the supply (DC = 90%)

Sl no.	V <sub>DC</sub> (V)	L <sub>se</sub> (mH)	pf	P <sub>in</sub> watt	P <sub>o</sub> watt	I <sub>THD</sub> in %	Loss (w)
1	3300	0	0.91	16150	6460	7.3	9690
2	3300	0.1	0.93	16150	6460	7.1	9690
3	3300	0.5	0.94	17423	6960	7.15	10440
4	3300	1	0.98	18000	7200	6.7	10800
5	3300	3	0.99	22500	9000	6.5	13500
6	3300	5	0.993	24300	9720	6	14580
7	3300	7	0.997	24670	9870	5.8	14800

**c. Discussions:**

Analysis of variation of power factor, THD and losses have been carried out using Boost converter. The input voltage used is unregulated. We observe from the results of simulation that the THD is enormously high (Nearly 40%) for 50% duty cycle operation of Boost converter. However, when duty cycle is increased is 90%, the values of THD are considerably lower. The variation in THD, losses and power factor are observed to (Tables 2.1 and 2.2) have the same trend which is that with increase in power factor, the losses are increasing and THD is decreasing.

## VII. POWER FACTOR IMPROVEMENT EFFECT ON A DYNAMIC LOAD

### a. Load description:

The load selected for the investigation of power factor improvement effect on dynamic load is a 3-phase Induction motor with name plate details as below:

#### NAME PLATE DETAILS:

POWER OUTPUT =2.2KW, 3HP, VOLTAGE=415V, CURRENT=4.8A, EFFICIENCY=79%

CONNECTION TYPE: DELTA, FULL LOAD PF = 0.7, N = 1440 RPM

### b. Reactive KVAR requirement for APFC:

The FL output of the motor is 2700w and at 0.72pf. The desired power factor was fixed for the APFC case at 0.99.

We know that the kVAR required for improvement is given by:

$$\text{kVAR} = P (\tan\Phi_1 - \tan\Phi_2) \quad \text{where } P = \text{active power of the load.} \quad \Phi_1 = \text{initial power factor angle}$$

$$\Phi_2 = \text{required power factor angle}$$

$$\text{kVAR} = 2.700 (\tan(\cos^{-1} 0.72) - \tan(\cos^{-1} 0.99)) = 2.5 \text{ kVAR}$$

#### **The capacitor bank is to be connected in star.**

Therefore,  $V_{ph} = V_L / \sqrt{3} = 415 / \sqrt{3} = 239.6V$ .

$$I_{Cph} = (\text{kVAR} * 1000) / (3 * V_{ph}) = 2500 / (3 * 239.6) = 3.47A$$

$$\text{Thus, } X_{Cph} = (V_{ph} / I_{Cph}) = 239.6 / 3.47 = 69\Omega.$$

$$\text{Therefore } C_{ph} = 1 / (2 * \pi * 50 * 69) = 46\mu F.$$

It was decided to use the required rating using 4 stages of capacitors.

The experiment was conducted after the calibration of the APFC under 2 cases. Case 1 was performed without the APFC connected to get the base data which are as tabulated in Table3.1. The in case 2 the APFC was connected and the data were obtained as tabulated in table 3.2.

**Table 3.1:** Experimental data without connecting APFC

Sl. No.	V <sub>L</sub> (v)	I (A)	W (Watts)	Torque (kg-m)	BHP	o/p(w)	pf	%η	I <sub>THD</sub>	Losses (w)
1	408	2.25	170	0	0	0	0.11	0	11.06	170
2.	400	2.4	800	0.3584	0.7356	541.1	0.5	67.64	10.04	258.9
3.	400	2.9	1440	0.7616	1.5419	1134.22	0.742	78.76	7.82	305.78
4.	394	3.4	1810	0.9856	1.9789	1455.67	0.78	80.42	7.3	354.33
5	394	3.9	2280	1.1984	2.382	1752.2	0.856	76.85	6.2	527.8

**Table 3.2 :** Experimental data with APFC

Sl. No.	V <sub>L</sub> (v)	I (A)	W (Watts)	Torque (kg-m)	BHP	o/p(w)	pf	%η	I <sub>THD</sub>	Losses (w)
1.	400	0.4	170	0	0	0	0.7	0	11.82	170
2.	400	1.266	745.65	0.358	0.735	540.6	0.85	72.5	10.49	205.05
3	400	1.97	1299	0.65	1.33	978.215	0.95	75.3	7.6	320.785
4	400	3.2	2215.8	1.2	2.377	1748.3	0.99	78.9	5.5	467.5

The images of the APFC and its connection to the circuit is shown in Fig 3.1



3.1 APFC with circuit connection for pf correction of an Induction motor

**c. Discussions:**

Variation of power factor and its effect have been analysed with incorporation of dynamic loads. A 3-phase IM was selected as dynamic load. A 3-phase Automatic Power Factor Controller (APFC) has been designed and constructed for studying the on-load performance. Also, the APFC has been calibrated using accurate reading meters (Voltmeter, Ammeters and Watt meters). The inaccuracy indications of APFC are within  $\pm 2\%$ .

The results of experimental investigations using above APFC set up show that the power factor can be improved up to 0.99. It was also observed that the trend with respect to the behaviour of THD and losses with variation of power factor is same with and without APFC. With increase in power factor THD is decreasing. Also, losses are increasing with increase in power factor & load.

## VIII CONCLUSION

An uncontrolled boost converter supplied from uncontrolled rectified supply was simulated with and without power factor improving capacitors. The effect of improving the power factor on the THD was studied and the filters were incorporated to reduce the level of THD. In the second phase a 3-phase APFC was designed and implemented for a dynamic load, a 3-phase IM. The APFC was calibrated and designed with very high precision components to ensure proper operation. The machine was experimentally analyzed with and without the APFC.

The performance verification of the simulation and hardware implementation has shown that:-

1. In case of circuits involving power electronic switching the even harmonic components, in particular the 2<sup>nd</sup> harmonic component, was predominant.
2. The use of appropriate filters with the circuit at output and input results in reduction of THD in input current.
3. Passive filters have limitations and are not sufficient to reduce the THD below the IEEE-519 standards. Active filters may be used in that case.
4. Results of experimental investigation using APFC shows that the power factor can be improved up to 0.99.
5. Increase in power factor in general decreases the THD.
6. At constant load, with increase in power factor, the losses are reduced.
7. Increase in power factor increases the losses. This is mainly due to increase in load current.
8. The trend with respect to the behavior of THD and losses with variation of power factor is same with and without APFC. However, the magnitude of THD is considerably reduced with increase in load.

## ACKNOWLEDGMENT

The authors of the paper would like to acknowledge the Management of BNMIT for providing the necessary research facilities.

## REFERENCES

- [1] Francis.M.Fernandez, P.S.Chandramohan Nair, "Influence of power factor compensating capacitor on estimation of harmonic distortion", 9<sup>th</sup> International conference on Electrical power quality and utilization" Barcelona, 9-11 October 2007.
- [2] IEEE standard 519-1992 Recommended Practices and Requirements for Harmonic control in Electric Power systems 1993.
- [3] Lorenzo Cividino, "Power factor, Harmonic Distortion; Causes, Effects and Consideration ", IEEE 1992 Page 506-514
- [4] Alexander Emanuel, Minghao Yang, "On the harmonic compensation in nonsinusoidal systems", IEEE transactions on Power Delivery, vol 8., No.1,

- [5] Fatih Başçiftçi and Ömer Faruk Hatay, “Microcontroller-controlled reactive power measurement and saving circuit design for residences and small scale enterprises”, Scientific research and essays Vol 5(16), pp 2312 – 2317, 18-Aug-2010.
- [6] K.Chatterjee, B.G.Fernandes and Gopal.K.Dubey, “An Instantaneous Reactive VA Compensator and Harmonic Suppressor System” IEEE Transactions on Power Electronics, Vol 14, No.2, 1999, pp 381-392.
- [7] Nicola Locci, Carlo Muscas, Sara Sulis, “On the measurement of power quality indexes for Harmonic distortion in the presence of capacitors”, IMTC – 2005 – Instrumentation and Measurement Technology Conference Ottawa, Canada, pp. Vol 3 1600-1605, May 2005.
- [8] “Operational Amplifiers and Linear IC” by Ramanand Gaekwad, PHI
- [9] “Linear Integrated Circuits” by Roy Choudary, New Age Publications
- [10] Renesas Electronics America Inc “ User manual for YMCRPRX62T – Microcontroller”.
- [11] “SPICE for circuits and Electronics”, Muhammed H.Rashid, PHI, 2002
- [12] “Power Electronics, Converters, Application and Design”, Ned Mohan, Undeland, Robbins Wiley.